

SHARP SERVICE MANUAL

CODE : 00ZPC1360SM/E



MODEL PC-1360

CONTENTS

1. Key layout	1	8. LSI description	5
2. Introduction	1	9. Test program	7
3. Specification	1	10. Other test items	9
4. System configuration	2	11. Circuit diagram	10
5. Block diagram	3	12. Parts and signals position	12
6. Power consumption	3	Parts list and guide	
7. Memory map	3		

1. KEY LAYOUT

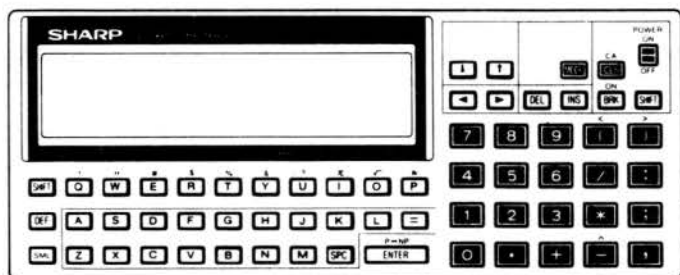

2. INTRODUCTION

- PC-1360 has the two RAM card slots. (for CE-210M ~ CE-2H32M). The RAM cards for PC-1350 (CE-201M ~ 202M) cannot be used.
- PC-1360 has the self check program in ROM. See 9. TEST PROGRAM.

3. SPECIFICATIONS

Model: PC-1360 Pocket Computer
Processor: 8 bit CMOS CPU
Programming: BASIC
Language:
System ROM: 136 K Bytes
Memory Capacity: RAM:

Held in RAM card (8KB)	System internal	960 Bytes	Can be ex- tended to 64KB using the two slots
	System area	1282 Bytes	
	User		
	Fixed Memory Area (A ~ Z, A\$ ~ Z\$)	208 Bytes	
	Program/Data Area	6558 Bytes	
	Reserve Area	144 Bytes	

Stack:	Sub-routine: 10 stacks
	FOR-NEXT: 5 stacks
	Function: 16 stacks
	Data: 8 stacks
Operators:	Addition, subtraction, multiplication, division, trigonometric and inverse trigonometric functions, logarithmic and exponential functions, angle conversion, square and square root, sign, absolute, integer, relational operators, logical operators etc...
Numeric Precision:	10 digits (mantissa) + 2 digits (expont).
Editing Features:	Cursor left and right, line up and down, character insert, character delete.
Memory Protection:	CMOS Battery backup.
Serial Input/Output Features:	
Standards:	Start-stop transmission (asyn-chronous) system. Only half duplex.
Baud Rates:	300, 600, 1200 Baud
Data Bits:	7 or 8 Bits
Parity Bits:	Even, odd, or no-parity
Stop Bit:	1 or 2 Bits
Connectors Used:	15-Pin connector (for external equipment)
Output Signal Level:	C-MOS level (4-6 Volts)
Interfacing Signals:	
	Inputs: RS, CS, CD, PAK
	Outputs: SD, RS, RR, ER, PRQ
	Others: SG, FG, VC

SHARP CORPORATION

Printer interface capability:

11 pin (For CE-126P, CE-124)

Graphics interface capability:

CE-140P commands (CIRCLE, PAINT etc.).

2 RAM card Slots: each card 2KB, 4KB 8KB, 16KB, or 32 KB.

Display: 4-line 24-digit liquid crystal display with 5x7 dot characters or 150x32 dot graphics.

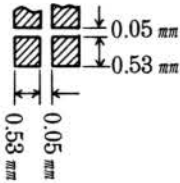

Key: 62 keys. Alphabetic, numeric, special symbols, and functions. Numeric pad. User defined keys.

Power Supply: 6.0 V DC: Lithium cells. type: CR-2032x2

Power Consumption: 6.0 V DC @ 0.03W
Approximately 120 hours of continuous operation under normal conditions (based on 10 minutes of operation or program execution and 50 minutes of display per hour at a temperature of 20°C). The time may vary slightly depending on usage and the type of battery used.

Operating

Temperature: 0°C – 40°C (32°F – 104°F)

Dimensions: 182(W) x 72(D) x 16(H) mm. 7-5/32" (W) x 2-27/32" (D) x 5/8"(H)

Weight: Approximately 220g (0.49 lbs.) (with cells and a RAM card)

Accessories: Hard cover, one 8KB RAM card (CE-212M), two lithium cells (built in), one keyboard template and operation manual.

Options:
Plug in RAM cards
2 KB(CE-210M)
4 KB(CE-211M)
8 KB(CE-212M)
16 KB(CE-2H16M)
32 KB(CE-2H32M)

Cassette Tape Recorder (CE-152)
Printer/Cassette Interface (CE-126P)
Printers (CE-140P, CE-515P, CE-516P) etc.

Copy Capability: RAM cards can be copied from slot 1 to slot 2.

4. SYSTEM CONFIGURATION

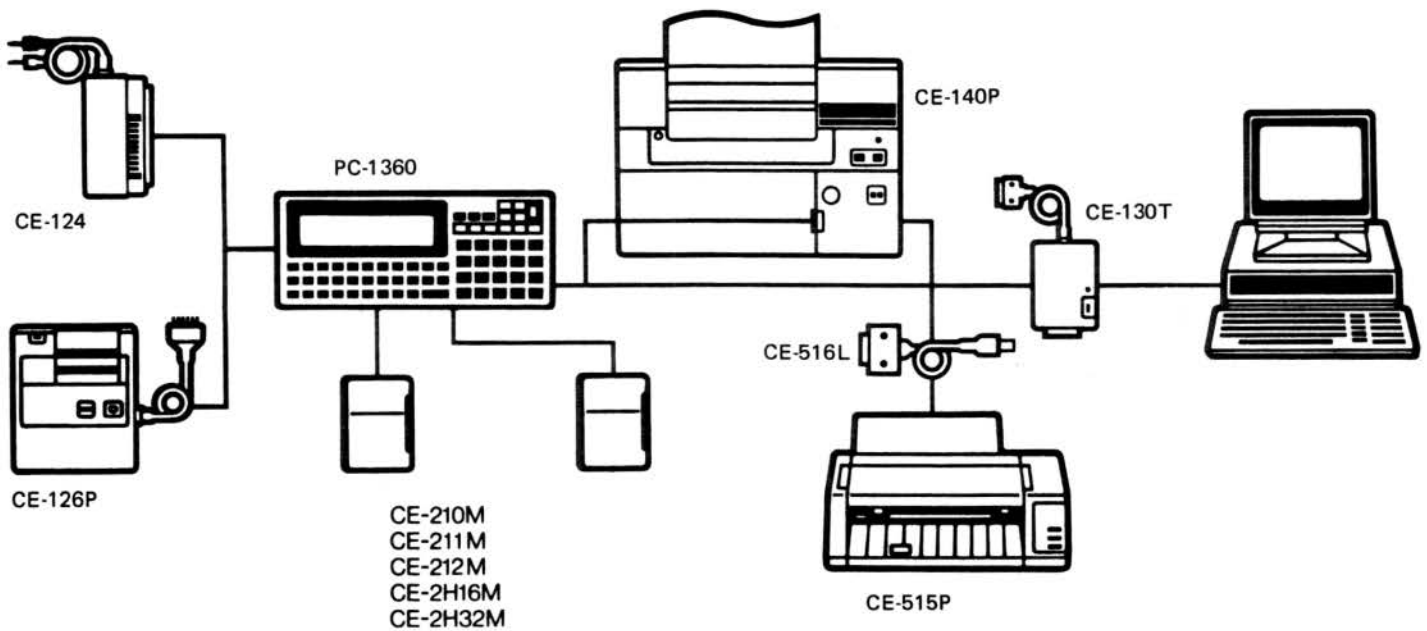

5. BLOCK DIAGRAM

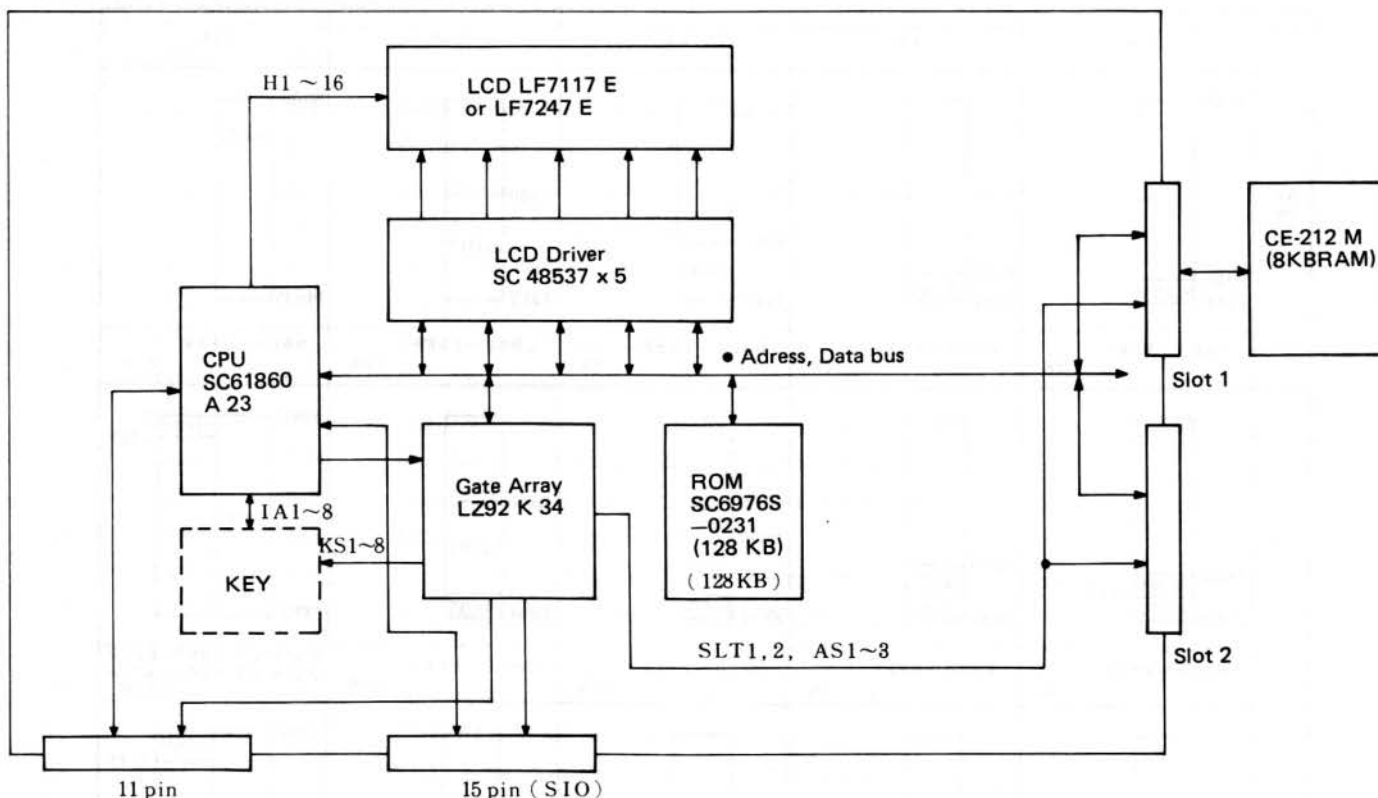

6. POWER CONSUMPTION

Power consumed for the PC-1360 under power off	25 μ A, max.
Power consumed for the PC-1360 during displaying	600 μ A, max.
Power consumed for the PC-1360 during arithmetical operation	4.3 mA, max.
Power consumed for the CE-212M	About 25 μ A, max.

As the above values are observed under the room temperature of 20°C, it may vary depending on environment.

- How to judge the life of the battery
 - PC-1350: Needs replacement when the terminal voltage drops below 5.2 volts (2.6 volts per battery cell).
 - CE-212M: Needs replacement when the terminal voltage drops below 2.5 volts.

7. MEMORY MAP

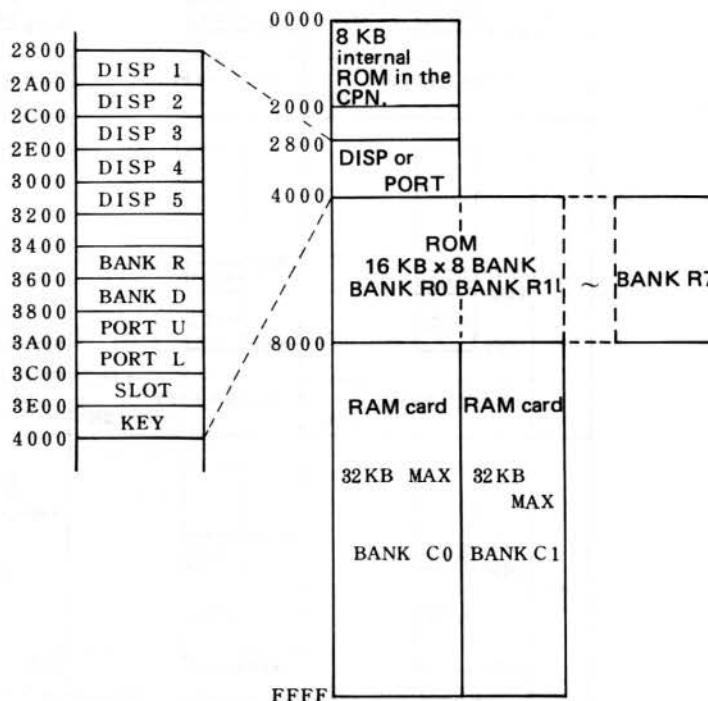

Up to two RAM cards can be used in this model, which should be interfaced through the slot-1 and slot-2. For there are five variety of RAM cards (2 KB to 32 KB), the following RAM card addresses are established according to the size of RAM cards combined.

MEMORY MAP FOR RAM CARDS

1 2	2 K	4 K	8 K	16 K	32 K
Not use					
	F800 ~ FFFF 2K	F000 ~ FFFF 4K	E000 ~ FFFF 8K	C000 ~ FFFF 16K	8000 ~ FFFF 32K
2 K					
	F000 ~ FFFF 4K	E800 ~ FFFF 6K	D800 ~ FFFF 10K	B800 ~ FFFF 18K	BANK C0 8000~FFFF BANK C1 8000~87FF 34K
4 K					
	E800 ~ FFFF 6K	E000 ~ FFFF 8K	D000 ~ FFFF 12K	B000 ~ FFFF 20K	BANK C0 8000~FFFF BANK C1 8000~8FFF 36K
8 K					
	D800 ~ FFFF 10K	D000 ~ FFFF 12K	C000 ~ FFFF 16K	A000 ~ FFFF 24K	BANK C0 8000~FFFF BANK C1 8000~9FFF 40K
16 K					
	B800 ~ FFFF 18K	B000 ~ FFFF 20K	A000 ~ FFFF 24K	8000 ~ FFFF 32K	BANK C0 8000~FFFF BANK C1 8000~BFFF 48K
32 K					
	BANK C0 E800~FFFF BANK C1 8000~FFFF 34K	BANK C0 E000~FFFF BANK C1 8000~FFFF 36K	BANK C0 E000~FFFF BANK C1 8000~FFFF 40K	BANK C0 C000~FFFF BANK C1 8000~FFFF 48K	BANK C0 8000~FFFF BANK C1 8000~FFFF 64K

8. LSI DESCRIPTION

8-1. SC61860A23 Microprocessor chip pin description

Pin No.	Symbol	In/Out	Description	Standby = power off
1	AO1	Out	Address bus A0, high during standby	
2	R \bar{W}	Out	Write clock, normally high	
3	ϕ AL	Out	Address latch. Used to latch the LCD drive latch address.	
4	TES	In	Test pin, normally set low.	
5	ϕ I	In	Oscillator input	
6	ϕ O	Out	Oscillator output	
7	RES	In	Reset input, active high	
8	XIN	In	Cassette signal input	
9	KON	In	ON/BRK key input, normally pulled down to low level.	
10	XOUT	Out	Out Cassette signal and buzzer signal output	
11	DIS	Out	Out LCD driver control, high during displaying	
12	HA	Out	LCD driver sync clock	
13	IA8	In/Out	Key input/strobe signal. Also used for the SIO PAK (Printer Acknowledge) input.	
14	IA7	In/Out	Key input/strobe signal, low during standby	
	}	}	}	
20	IA1	In/Out	Key input/strobe signal, low during standby	
21	IB8	In	SIO CD (request to send from the other end)	
22	IB7	In	SIO CS (send enabled from the other end)	
23	IB6	In	SIO RD (receive data)	
24	IB5	In	ACK input on 11-pin interface	
25	IB4	In	DIN input on 11-pin interface	
26	IB3	In	DOUT input on 11-pin interface	
27	IB2	In	IO2 input on 11-pin interface	
28	IB1	In	IO1 input on 11-pin interface	
29	VM	In	LCD drive power supply	
30	VA	In	LCD drive power supply	
31	GND	In	(+) power supply	
32	H1	Out	LCD backplate signal, 4-level pulse (1/16 duty) during displaying	
	}	}	}	
47	H16	Out	LCD backplate signal, 4-level pulse (1/16 duty) during displaying	
48	VB	In	LCD drive power supply, high during standby	
49	VDIS	In	LCD drive power supply, high during standby	
50	VCC	In	LCD drive power supply, high during standby	
51	VDC	Out	LCD drive power supply, high during standby	
52	VGG	In	(-) power supply	
53	08	In/Out	Data bus, D7, normally high impedance	
	}	}	}	
60	01	in/Out	Data bus, D0, normally high impedance, 8000H maximum	
61	FO5	Out	RAM, LCD driver, system ROM chip enable (CEC)	
62	FO4	Out	RAM card chip enable (CER)	
63	FO3	Out	RAM card bank select (BA)	
64	FO2	Out	SIO SD (send data)	
65	FO1	Out	Not used.	
66	BO8	Out	Address bus, A15, high during standby	
	}	}	}	
78	BO1	Out		
74	A08	Out		
	}	}	}	
80	A02	Out	Address bus, A1, high during standby	

8-2. LS82K34 gate array pin description

Pin No.	Symbol	In/Out	Description	Standby = power off
1	CEC	In	Address 0000-7FFF chip enable, active low	
2	CER	In	Address 8000-FFFF chip enable, active low	
3	DO0	In	Data bus input, D0	
4	4	4	4	
6	DO3	In	Data bus input, D3	
7	GND	In	(-) supply	
8	PO1	Out	IO1 output on 11-pin interface, pch open output	
9	PO2	Out	IO2 output on 11-pin interface, pch open output	
10	PO3	Out	DOUT output on 11-pin interface and SIO PRQ (Printer ReQuest output), pch open output	
11	PO4	Out	DIN output on 11-pin interface and SIO PRQ (Printer ReQuest output), pch open output	
12	PO5	Out	BUSY output on 11-pin interface, pch open output	
13	PO6	Out	SIO ER. High with an OPEN command	
14	PO7	Out	SIO RR (main unit ready to receive)	
15	PO8	Out	SIO RS (main unit send request)	
16	AS1	Out	System ROM address A14 and RAM card slot A11	
17	AS2	Out	System ROM address A15 and RAM card slot A12	
18	AS3	Out	System ROM address A16 and RAM card slot A13	
19	AD16	Out	Not used.	
20	AD17	Out	Not used.	
21	SLT1	Out	RAM card slot-1 chip enable	
22	SLT2	Out	RAM card slot-2 chip enable	
23	RAM	Out	Not used.	
24	NC			
25	DSP1	Out	LCD driver chip enable	
26	26	26	26	
29	DSP5	Out	LCD driver chip enable	
30	VCC	In	(+) power supply	
31	GND	In	(-) power supply	
32	KS1	Out	Key strobe, Pch open output	
33	33	33	33	
39	KS8	Out	Key strobe, Pch open output	
40	R/W	In	Write clock	
41	A9	In	Address input, A9	
42	42	42	42	
47	A15	In	Address input, A15	
48	BA	In	RAM card bank select	

Description of the SC43537 Display LSI

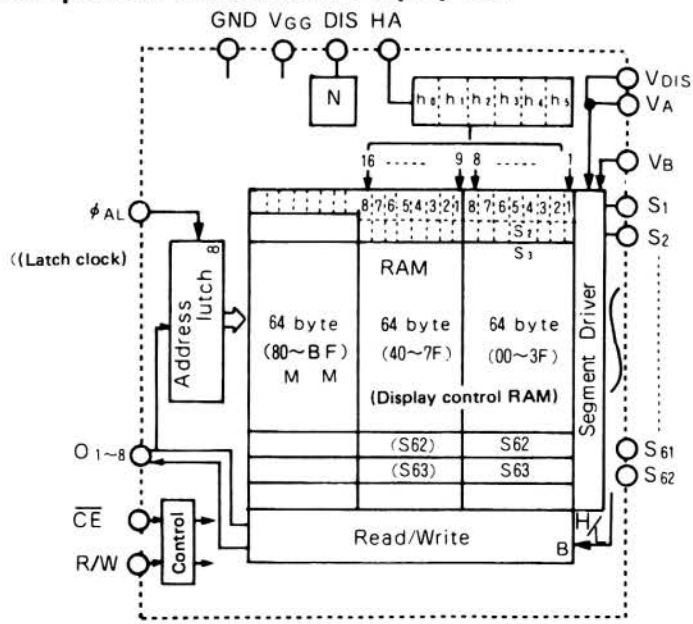

The LCD operates under 1/16 duty. 80-pin

Timing

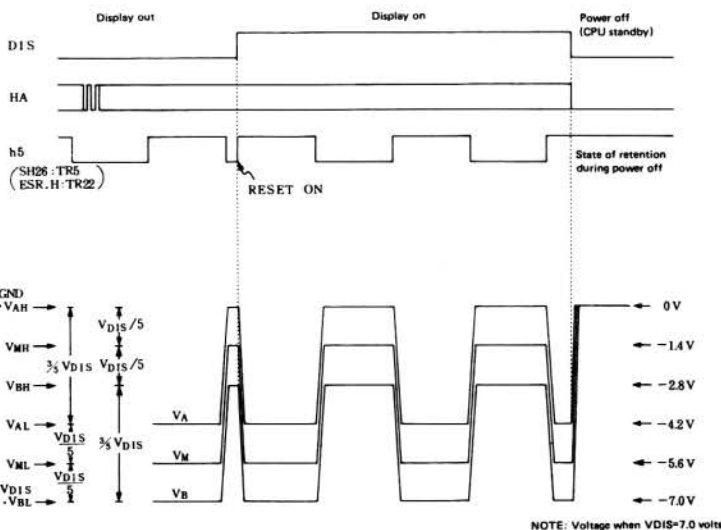

Counter and segment waveforms

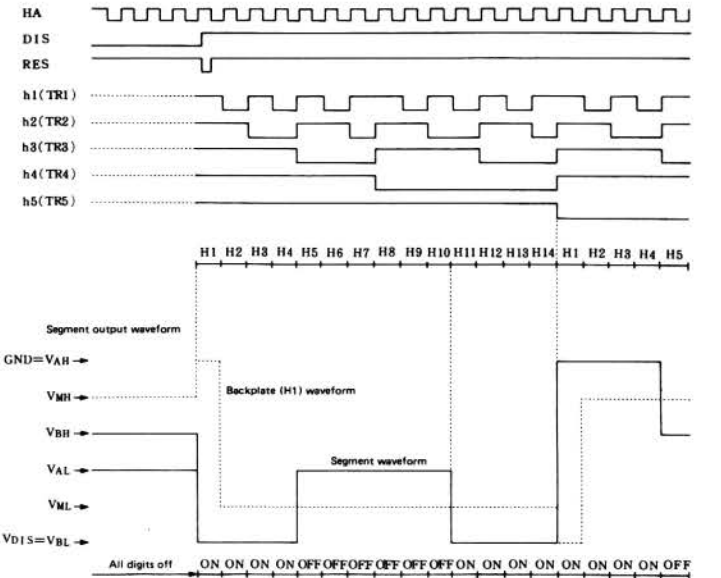

	h5 = 1	h5 = 0
All digits off (DIS = L)	V _{AL}	V _{BH}
On	V _{BL}	V _{AH}
Out	V _{AL}	V _{BH}

9. TEST PROGRAM

The PC-1360 has the test program.

- Test items
 - (1) LCD display
 - (2) RAM card (slot-1, slot-2) read after write
 - (3) Keys
 - (4) 11-pin I/O signal test
 - (5) 15-pin I/O signal test

Tools required

Special tool UKOGC3020CSZZ used for the above items (4) and (5). (price rank : BC)

Test operation

Set the PC-1360 to be tested in the RUN mode, power off, then make key entry according to the flowchart shown below.

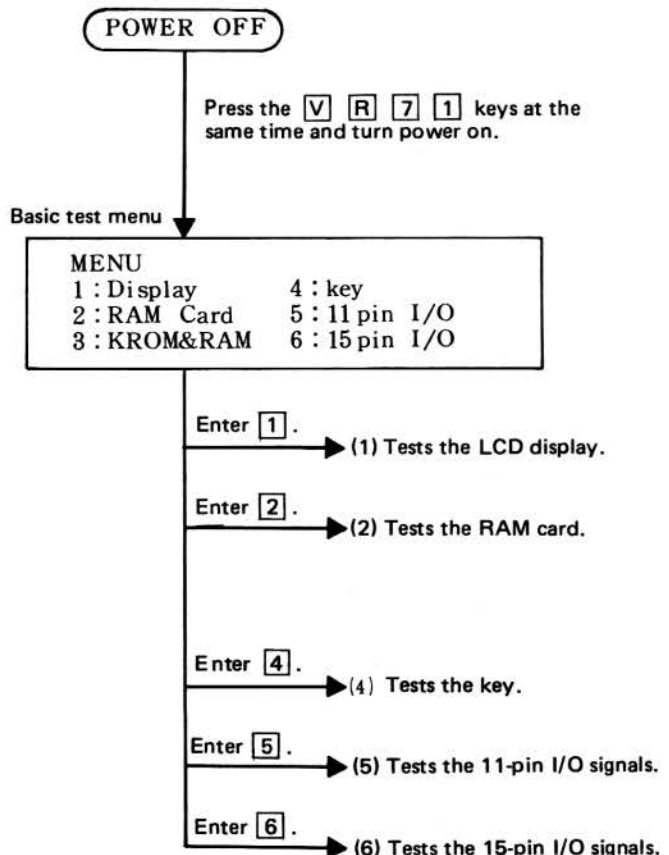

NOTES:

- 1: Power can be turned off only while the basic menu is on display.
- 2: The contents of the RAM are destroyed after the test.
- 3: If the specified test program were not to start, check the key performance first.
- 4: In the menu, "KROM & RAM" is displayed. But this test is only for Japan.

● Test description

(1) LCD display test

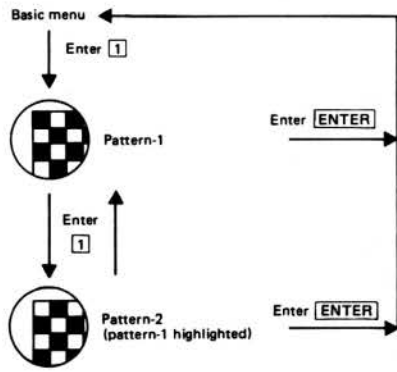

After the above operation, visually check the LCD.

(2) RAM card test

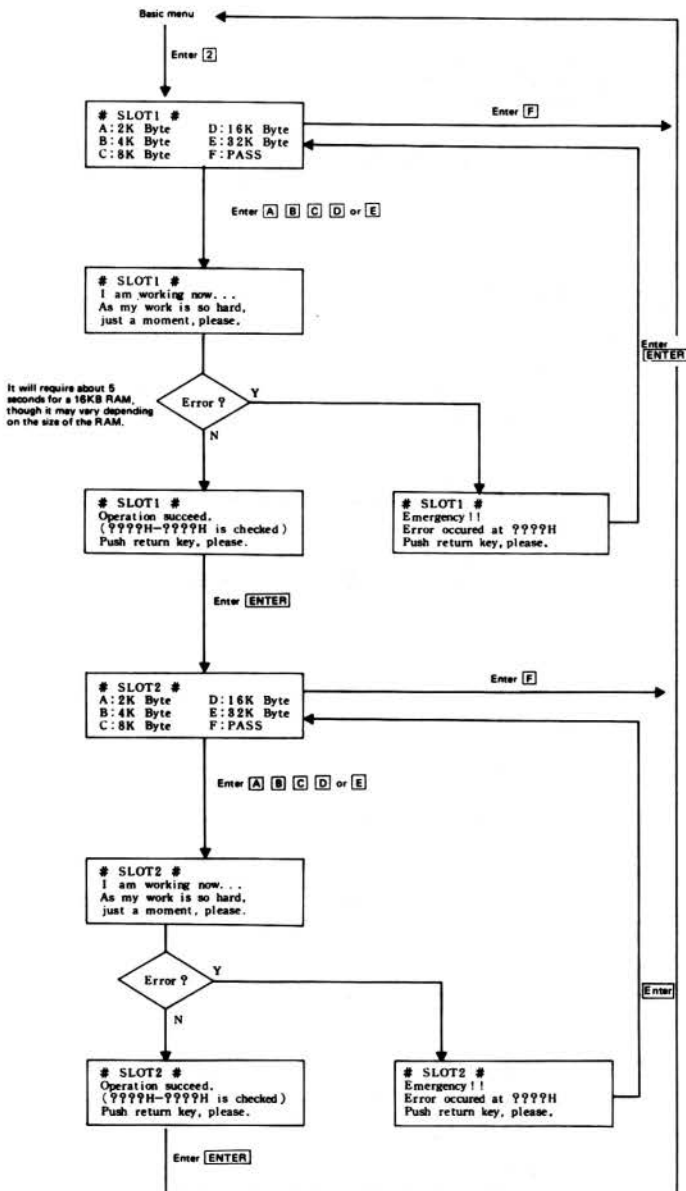

(3) Key test

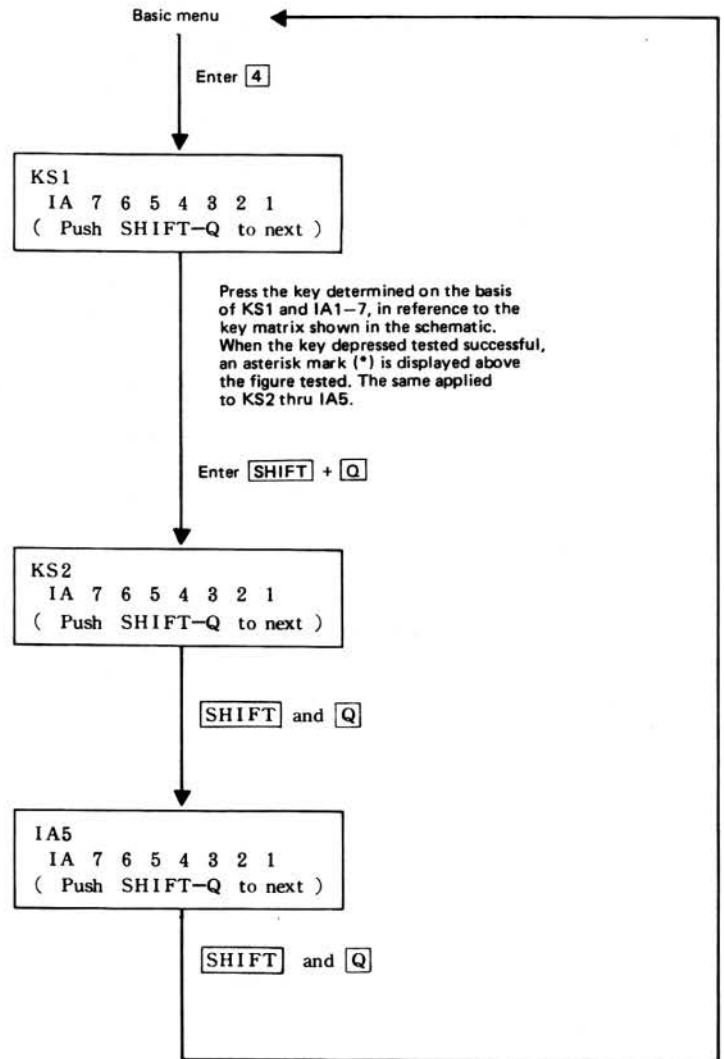

NOTE:

- 1: Since the slot-1 is first tested and then the slot-2 for the RAM card test, it is not possible to test only the slot-2. On the other hand, it is possible to test only the slot-1. The slot-2 test can be passed after the slot-1.
- 2: If the 4KB test is commanded for the 8KB RAM card, only the 4KB portion of the RAM is tested. In otherwise, case, it will result in an error.

(4) 11-pin I/O signal tests

Fasten the 11-pin test connector to the 11-pin connector located on the left side of the PC-1360 with the parts side facing up.

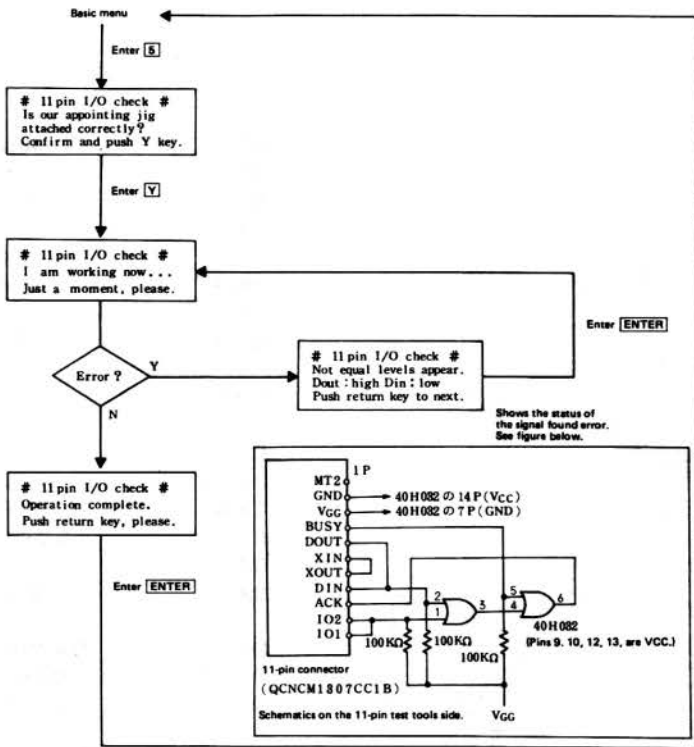

NOTE:

- 1: The message "Operation complete" will appear at the end of the test and it will be displayed regardless of error involvement.
An error has to be checked on the error frame.
- 2: It will not evoke an error if the signals being tested were shorted.

Description of 11-pin and 15-pin I/O signal test

The signals described on the left are turned high to low in their order of appearance, to check if it matched the signal on the right.

- | | |
|---------------|---------------|
| • 11-pin test | • 15-pin test |
| 1 Xout → Xin | 1 RR → CD |
| 2 IO1 → IO2 | 2 RS → CS |
| 3 IO2 → IO1 | 3 SD → RD |
| 4 Dout → Din | 4 PRQ → PAK |
| 5 Din → Dout | 5 ER → RAK |
| 6 Busy → Ack | |

(5) 15-pin I/O signal tests

Fasten the 15-pin test connector to the 15-pin connector located on the right side of the PC-1360 with the parts side facing up.

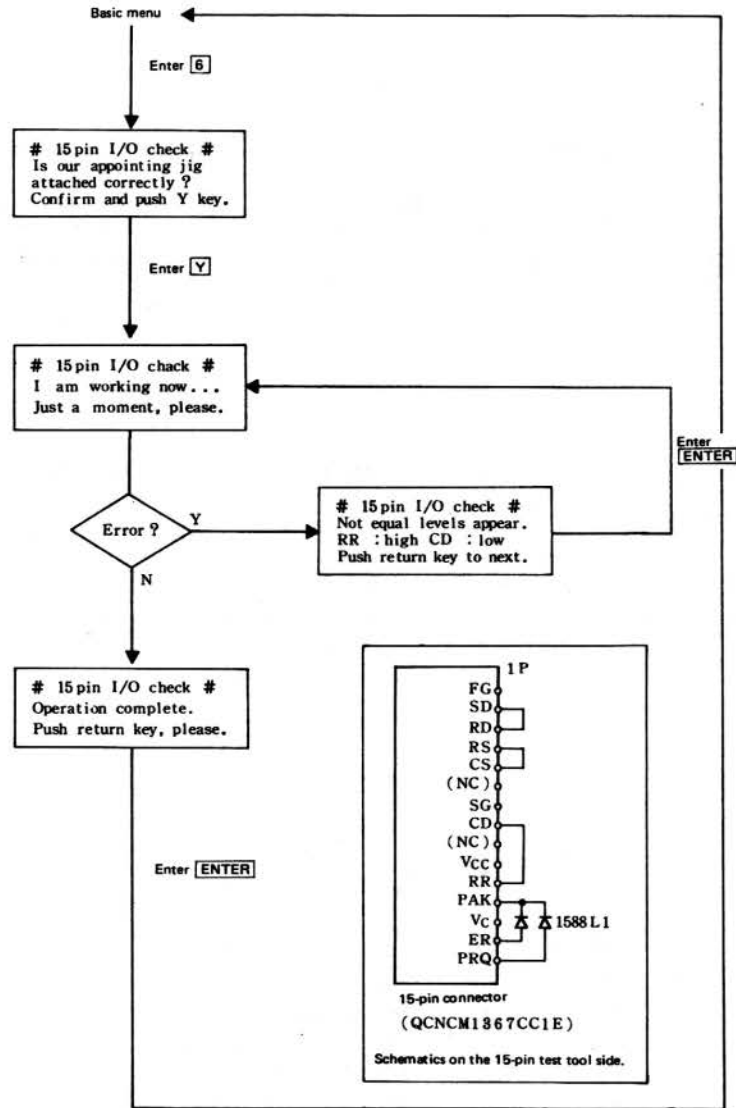

NOTE:

- 1: The message "Operation complete" will appear at the end of the test and it will be displayed regardless of error involvement.
- 2: It will not evoke an error if the signals being tested were shorted.

10. OTHER TEST ITEMS

(1) Continuity test

The resistance between the slot-2 side static panel and the right upper edge of the panel surface. It has be below 5 ohms.

(2) Auto power-off test

- ① Press the ALL RESET key with power on, and type **[Y]**.
- ② Check that is displayed.
- ③ Leave it for 15 minutes, then check that the display went off.

11. CIRCUIT DIAGRAM

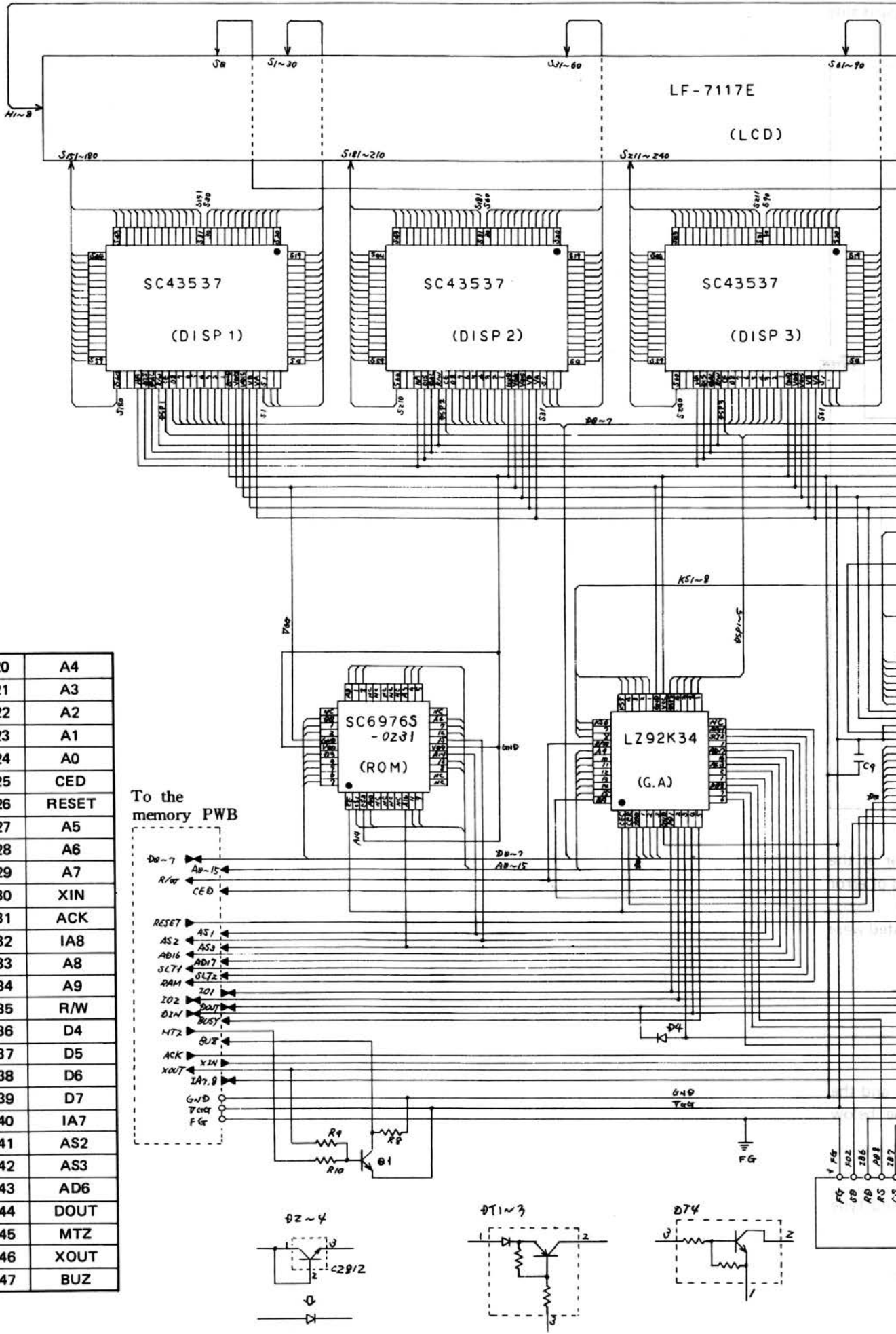

1	A10	20	A4
2	A11	21	A3
3	A12	22	A2
4	A13	23	A1
5	A14	24	A0
6	A15	25	CED
7	RAM	26	RESET
8	SLTZ	27	A5
9	D0	28	A6
10	D1	29	A7
11	D2	30	XIN
12	D3	31	ACK
13	SLT1	32	IA8
14	IO1	33	A8
15	IO2	34	A9
16	DIN	35	R/W
17	BUSY	36	D4
18	AD17	37	D5
19	AS1	38	D6
		39	D7
		40	IA7
		41	AS2
a	GND	42	AS3
b	VGG	43	AD6
c	FG	44	DOUT
		45	MTZ
		46	XOUT
		47	BUZ

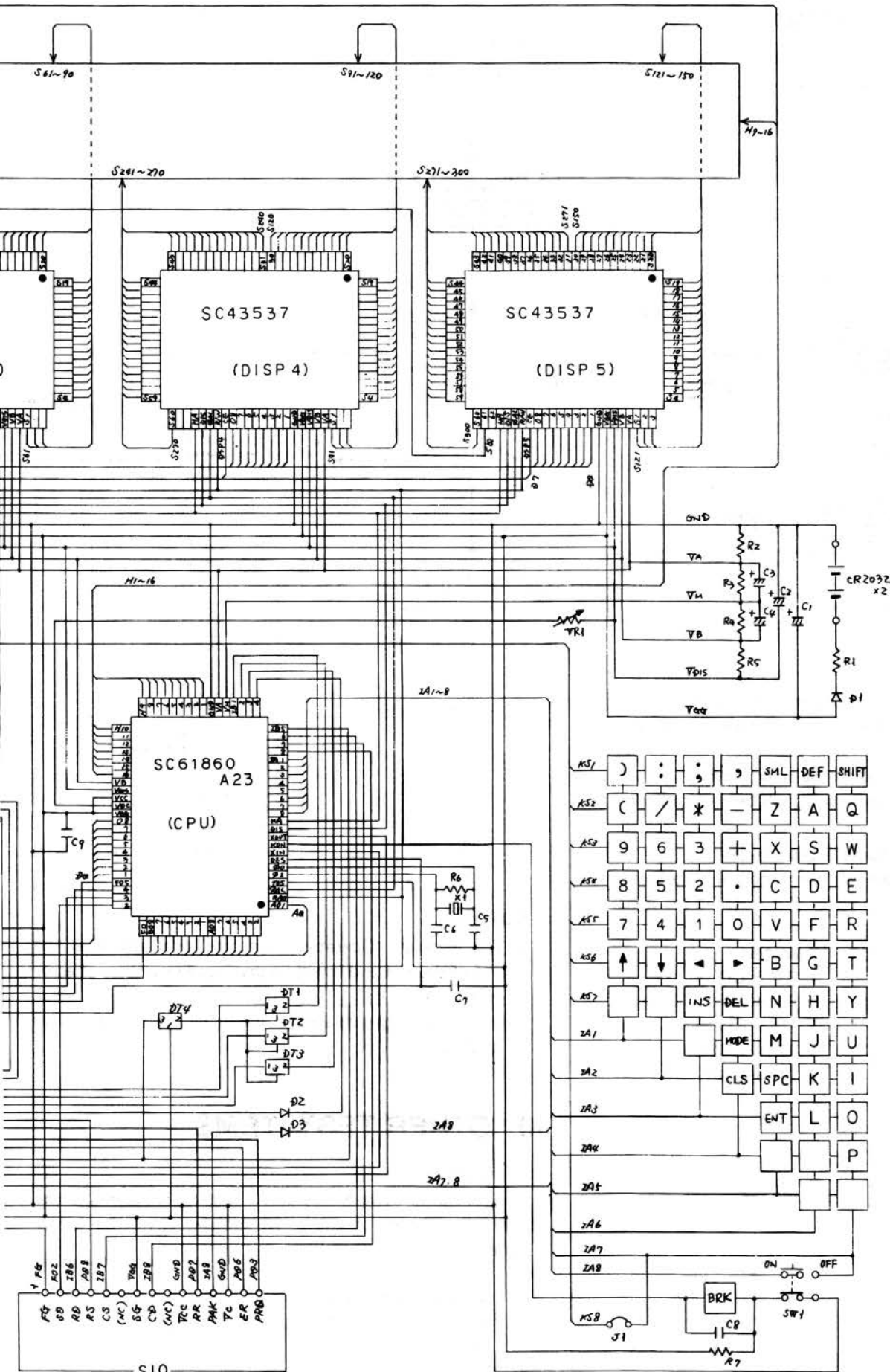

R1	10Ω
R2	30K
R3	10K
R4	10K
R5	30K
R6, 7	1M
R8	4.7K
R9, 10	100K
VR1	20K
C1	3.3μ
C2 ~ 4	1μ
C5, 6	100P
C7	0.033μ
C8	0.01μ
C9	0.1μ
D1	DAN202
D2 ~ 4	CZ812
Q1	CZ812
X1	CSB768DMT
DT1 ~ 3	FMJ1
DT4	DTC144Y

J1 CLOSE : Export type
 OPEN : JAPAN

12. PARTS AND SIGNALS POSITION

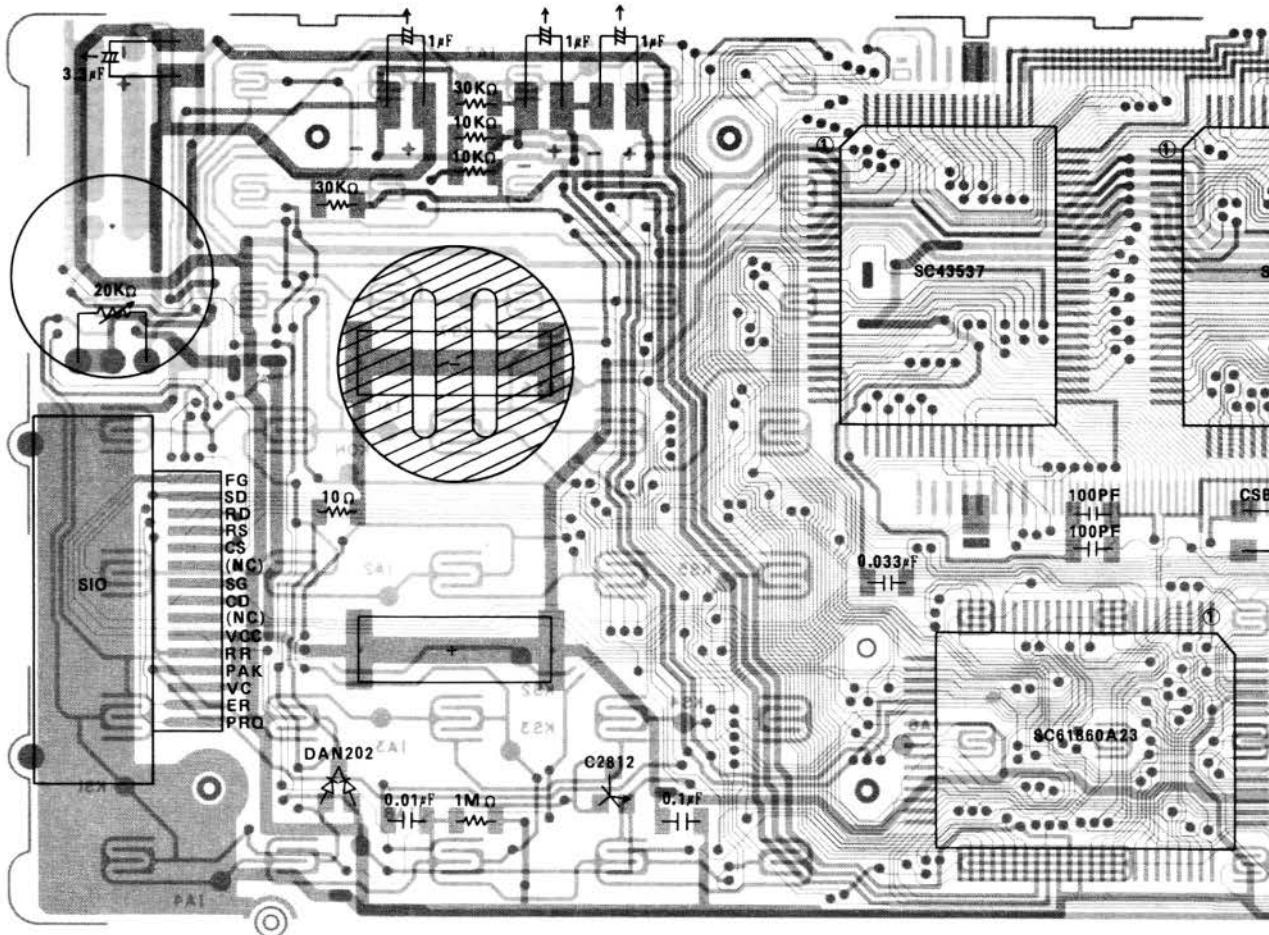
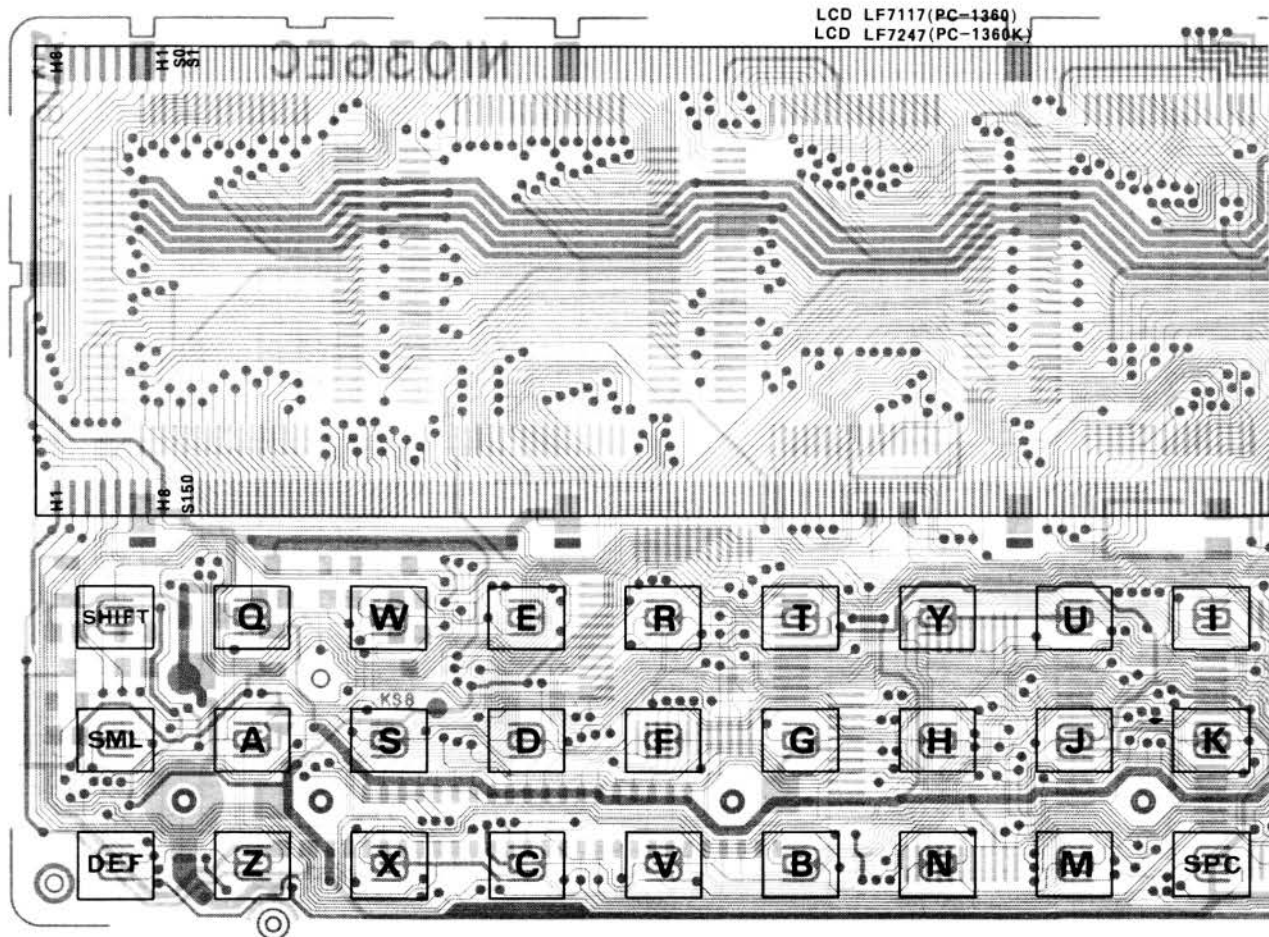

1. The parts must be...
2. CSB768DMT...
3. 1μF and 3.3μF

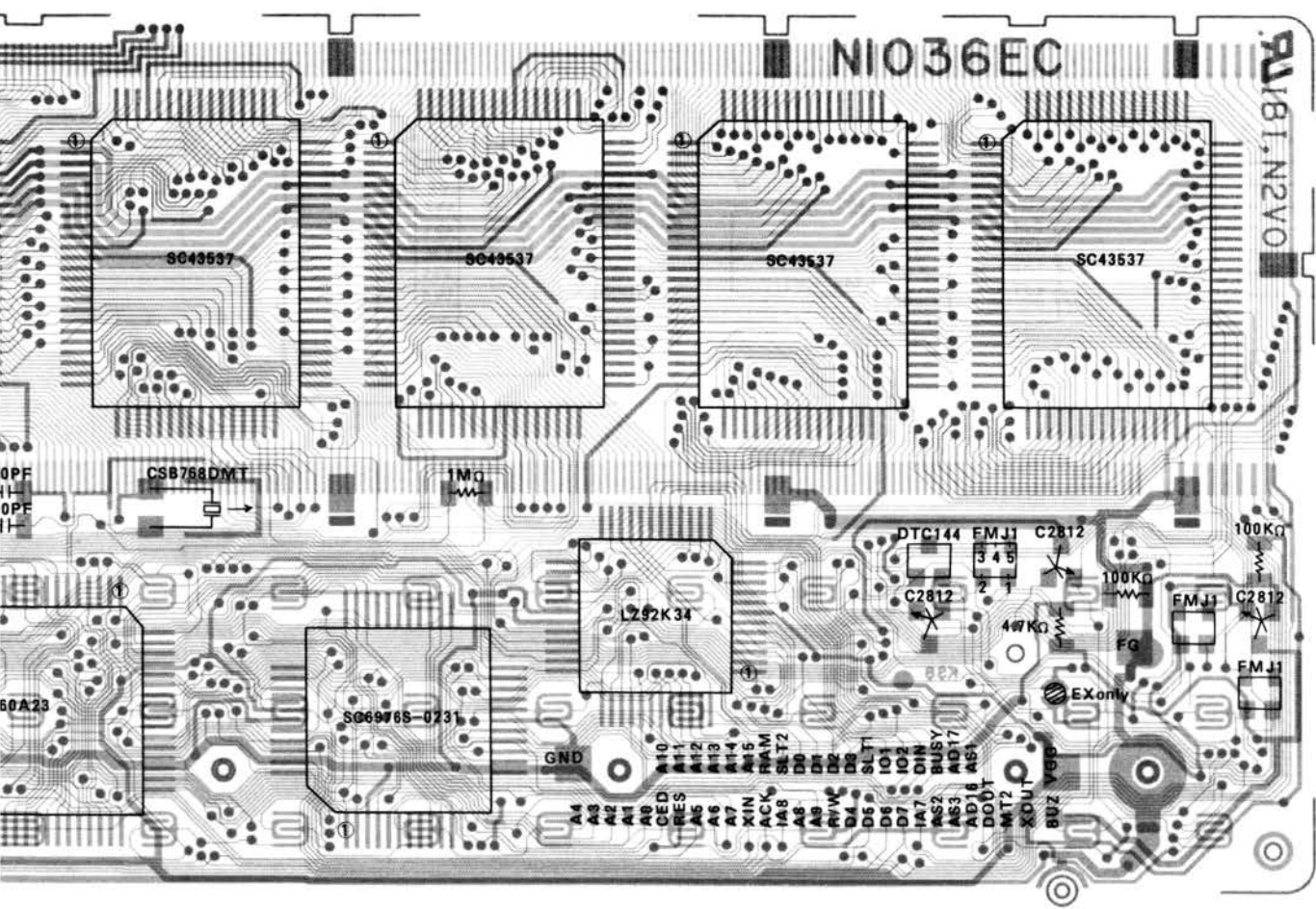
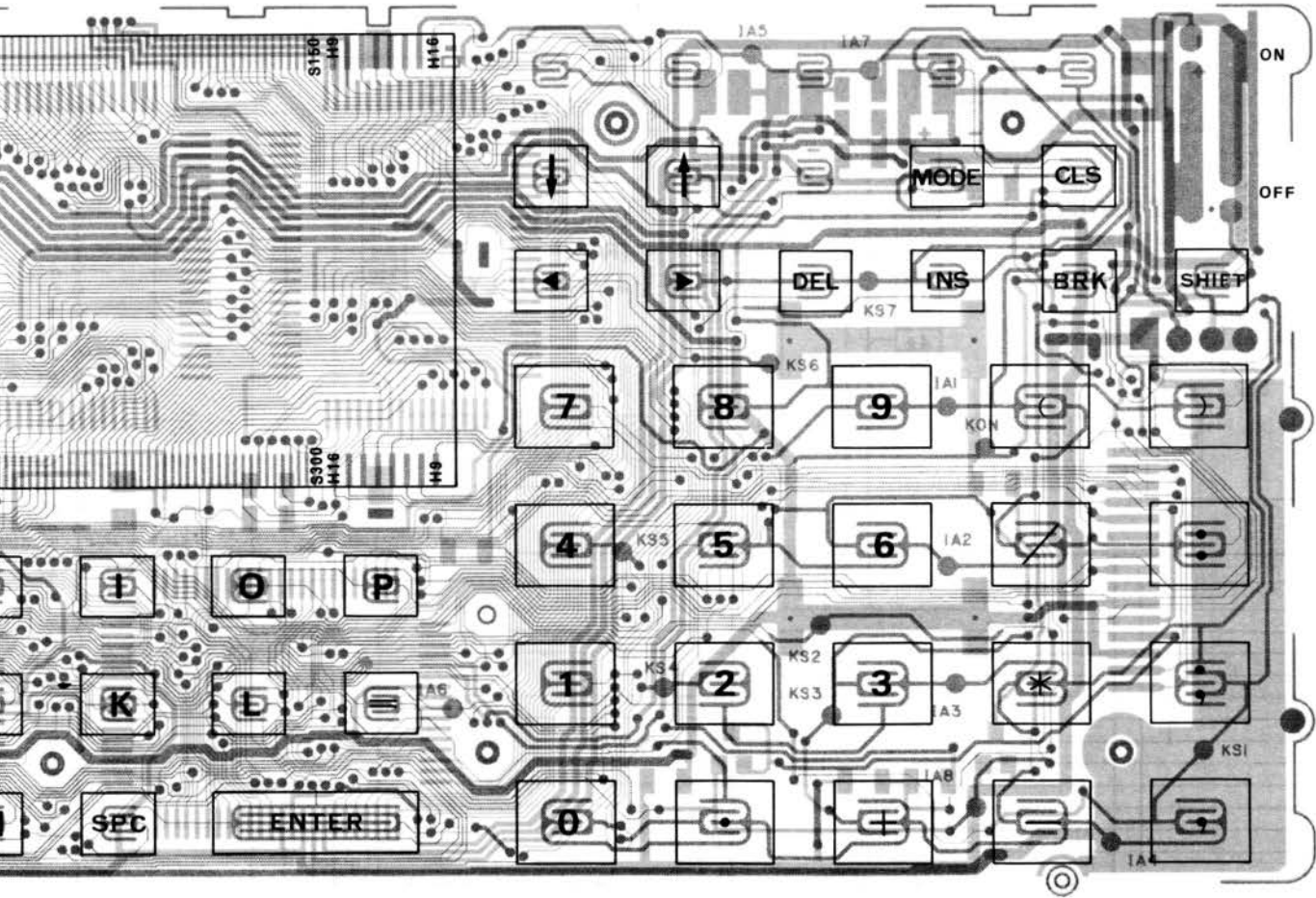

1. The parts must be installed as "↑" direction.
2. CSB768DMT must be installed within [] .
3. 1μF and 3.3μF capacitors must be installed within PWB.

Circuit Diagram (Memory PWB)

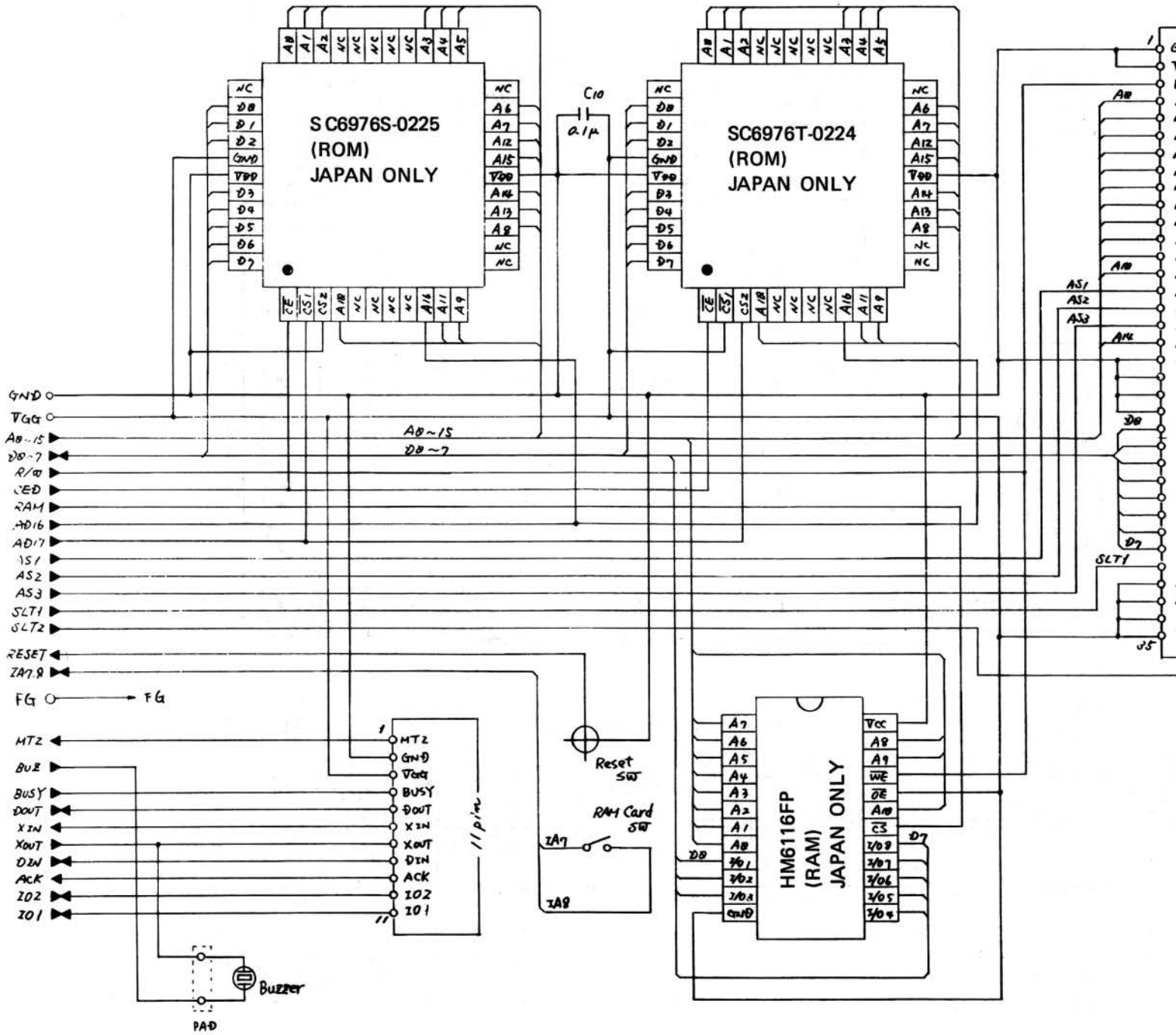

LCD Matrix

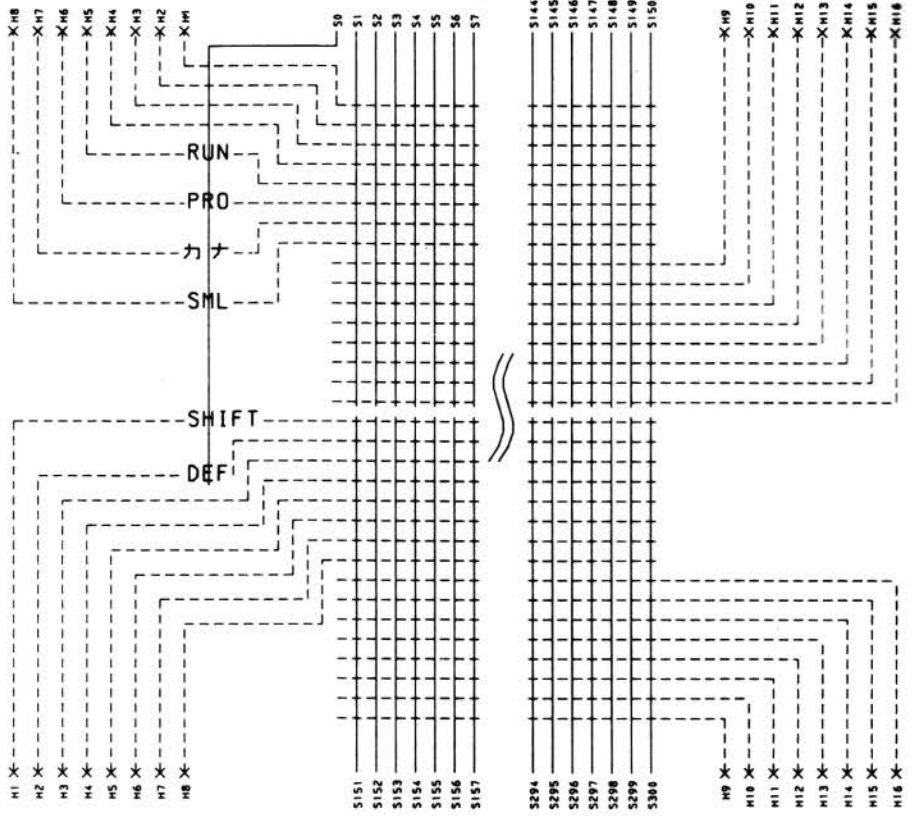
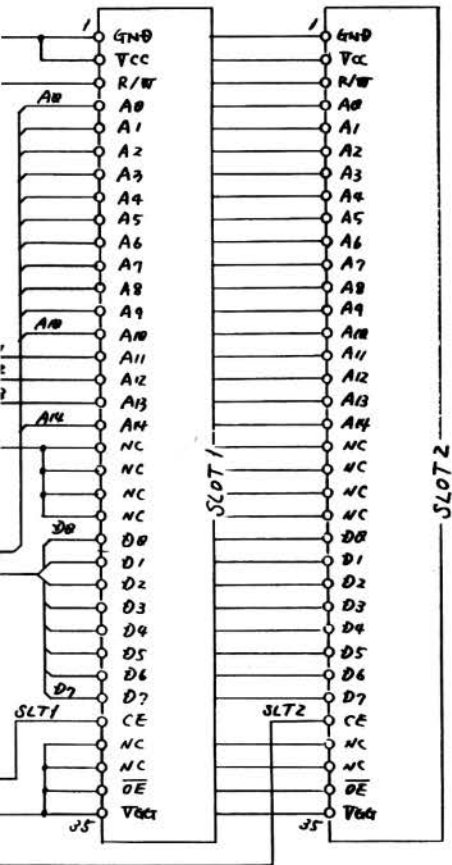

Memory PWB

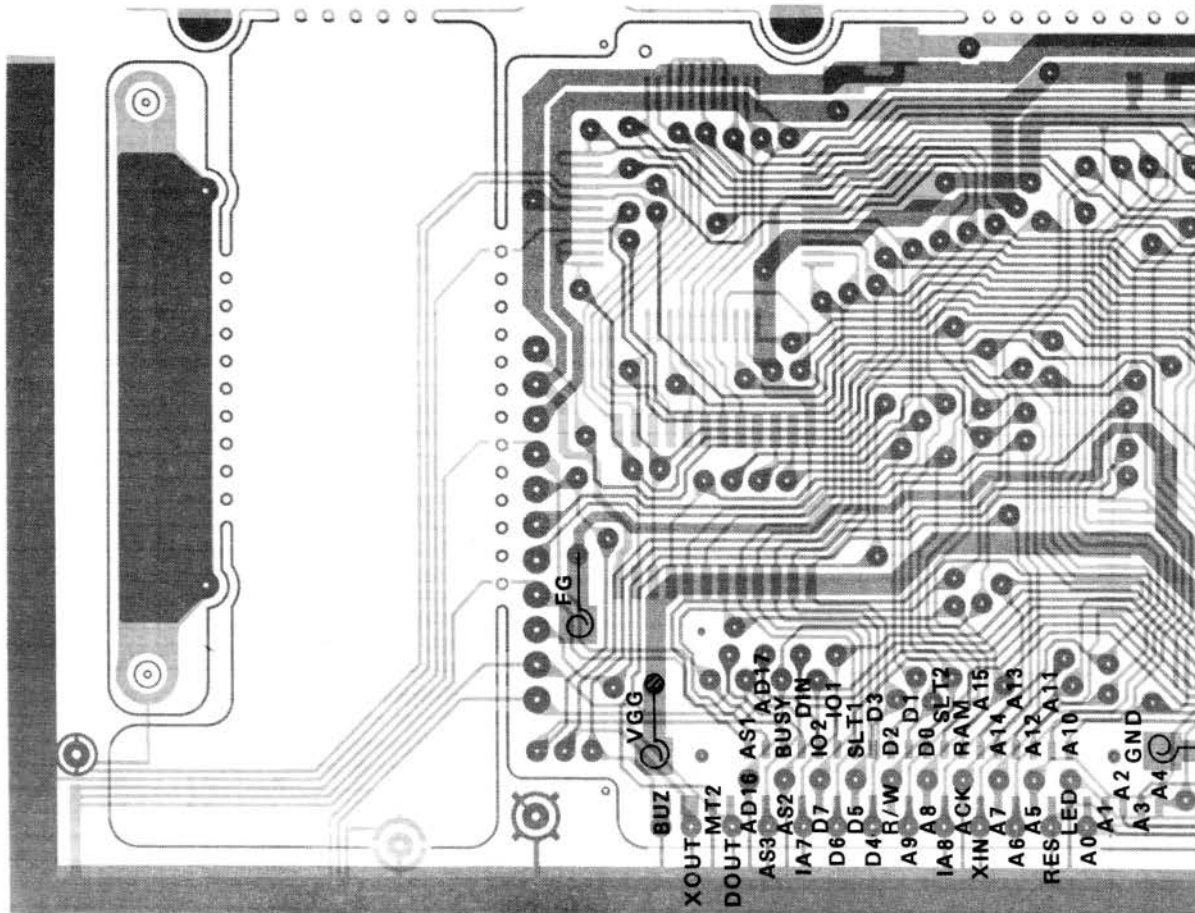
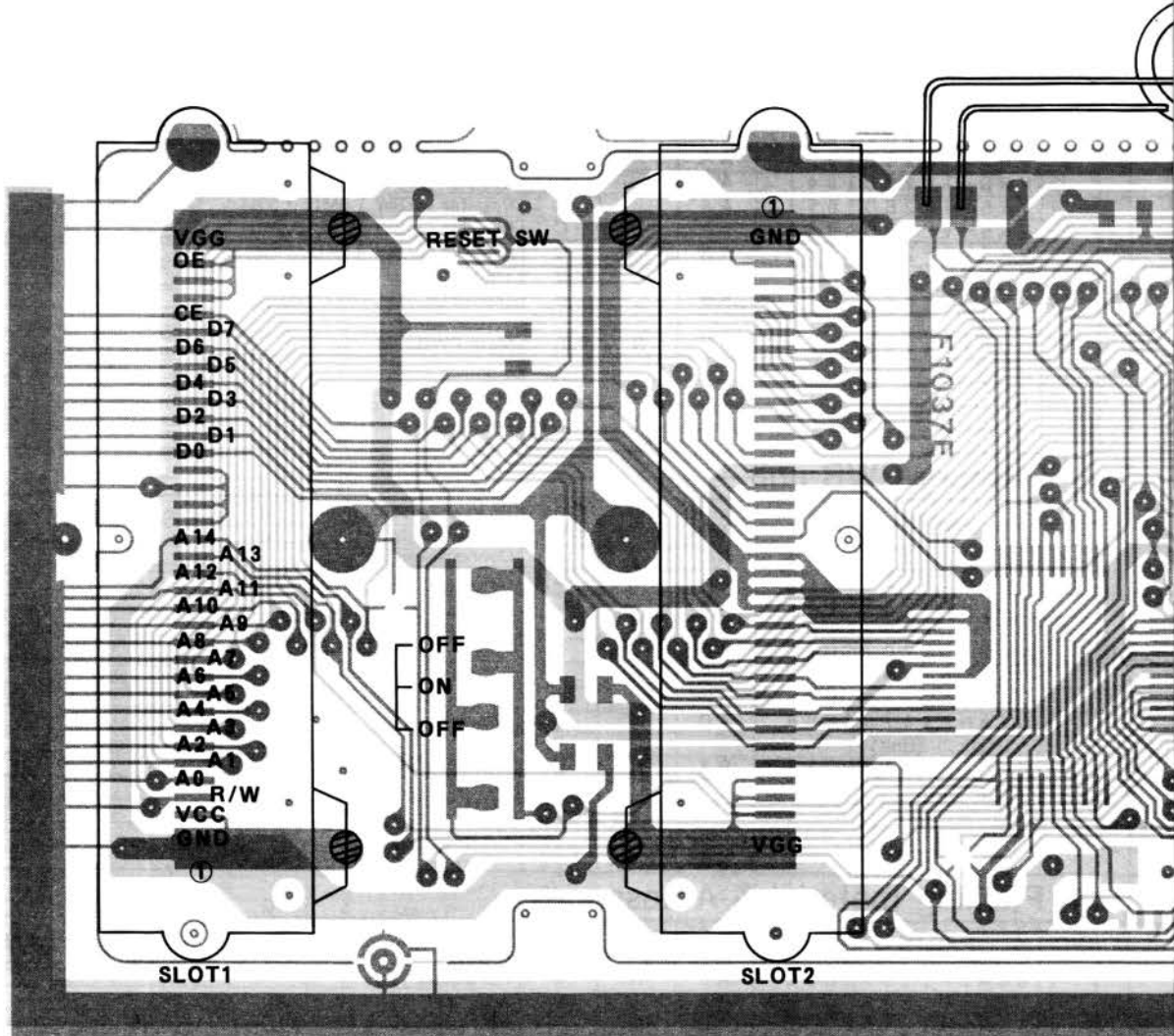

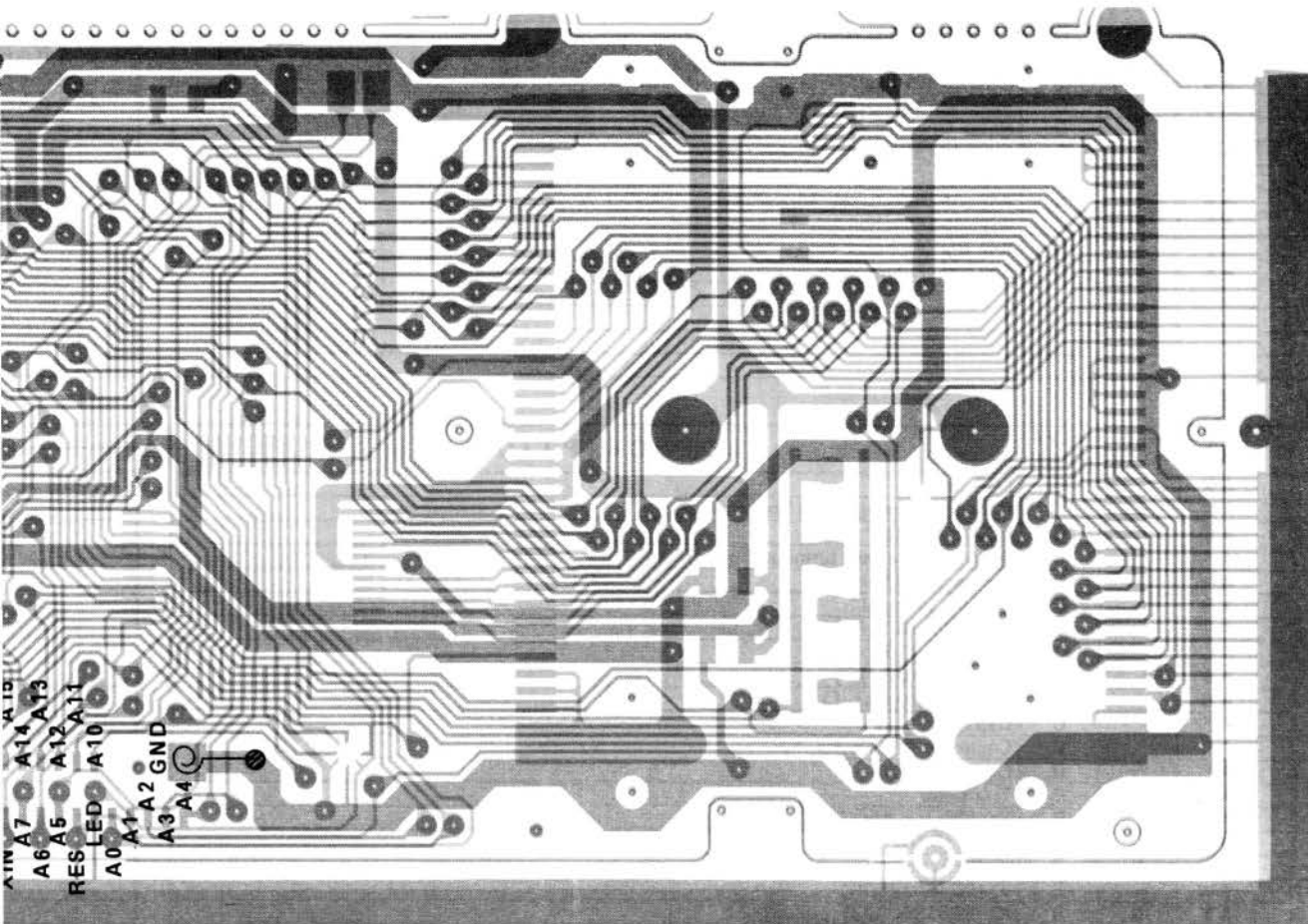
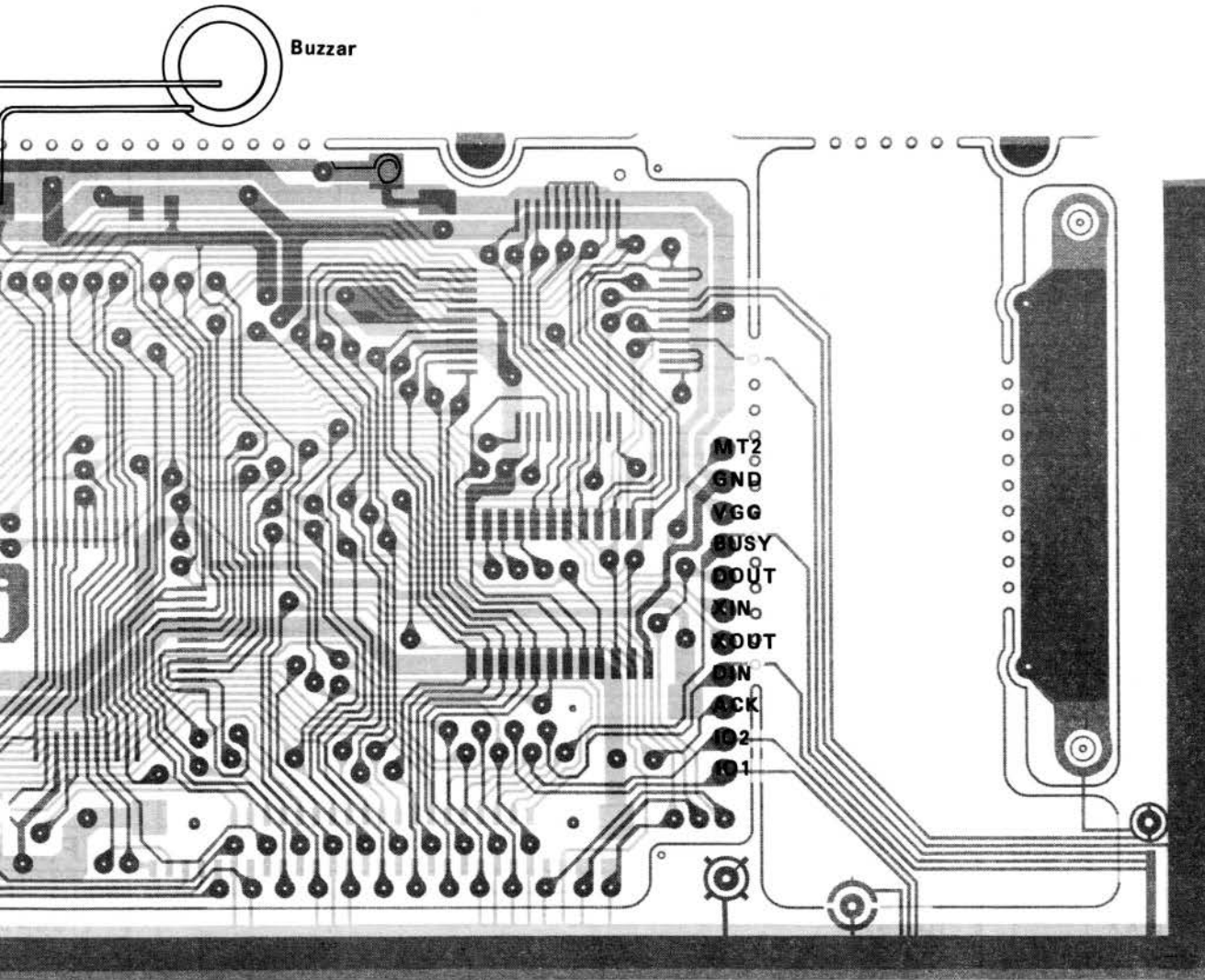

13. PARTS LIST & GUIDE

1 Exteriors

NO.	PARTS CODE	PRICE RANK	NEW MARK	PART RANK	DESCRIPTION
1	GFTAU1006ECSA	AF	N	D	Card cover
2	HPNLC1004ECZZ	AB	N	C	Panel
3	PTPEH1137CCZZ	AA		D	Tape
4	LFIX-1190CC01	AC		C	Card fixing plate
5	XBBSF20P06000	AA		C	Screw (2×6)
6	GCABA1015ECSA	AF	N	D	Bottom cabinet
7	GLEGG1031CCZZ	AA		C	Rubber foot
8	QTANZ1478CCSA	AC	N	C	Power terminal
9	LHLDZ1215CC01	AC		C	Connector holder
10	PGUMS1549CCZZ	AE		C	PWB card connector
11	QCNTM1042CCZZ	AA		C	Slide switch terminal
12	MSLIP1001ECSA	AB	N	C	Card cover switch knob
13	PTPEH1213CCZZ	AB		C	Tape
14	RALMB1030CCZZ	AD		B	Buzzer
15	LX-BZ1163CCZZ	AA		C	Screw (2×8.8)
16	LANGK1008ECZZ	AC	N	C	Pressure angle
17	PSPAP1005ECZZ	AA	N	C	Pressure spacer
18	DUNTK1142ECZZ	BA	N	E	Memory PWB unit
19	LX-BZ1120CCZZ	AA		C	Screw
20	QTANZ1406CCZZ	AB		C	Battery terminal (+⊖)
21	LANGK1558CCZZ	AE		C	Angle A
22	MSPRC1300CCZZ	AA		C	Card cover spring
23	TLABZ2240CCZZ	AA		C	Battery cover label
24	LX-BZ1184CCZZ	AA		C	Screw (2×5.5)
25	PGUMS1008ECZZ	AB	N	C	Connector rubber B
26	PGUMS1007ECZZ	AB	N	C	Connector rubber A
27	LANGK1566CCZZ	AC		C	Angle
28	LX-BZ1147CCZZ	AA		C	Screw (2×4.5)
29	QCNCW1385CC1B	AH		C	Connector (12pin)
30	PSHEZ1012ECZZ	AA	N	C	Nut fixing sheet
31	LX-NZ1010CCZZ	AA		C	Nut (2mm)
32	LCHSS1001ECZZ	AE	N	C	Chassis
33	QCNCW1368CC1E	AM		C	Connector (15pin)
34	DUNTK1116ECZZ	BV	N	E	Main PWB unit
35	PGUMM1548CCZZ	AH		C	Spring rubber
36	PGUMS1550CCZZ	AC		C	LCD connector rubber
37	DUNT-8038CCZZ	AX		E	LCD unit
38	PTPEH1039CCZZ	AA		C	LCD fixing tape
39	PFLV1545CCZZ	AE		C	Polarized filter
40	PSLDP1473CCZZ	AC		C	Display mask
41	PFLW1519CCZZ	AD		C	Acryl filter
42	GFTAA1287CCSB	AB	N	D	Cover for 15pin connector
43	DUNTG1140ECZZ	AX	N	D	Top cabinet unit
44	MSLIP1020CCSA	AB		C	Slide switch knob A
45	PGUMM1594CCZZ	AB		C	Reset spring rubber
46	TLABM1055ECZZ	AB	N	C	Name label
50	JKNBZ1909CC01	AF		C	Key top (SHIFT key 48pcs/1set)
51	JKNBZ1916CC01	AF		C	Key top (CLS key 48pcs/1set)
52	JKNBZ1874CC03	AF		C	Key top (MODE key 48pcs/1set)
53	JKNBZ1874CCSC	AF	N	C	Key top (Function key 7×4pcs/1set)
54	JKNBZ1873CCSH	AF	N	C	Key top (Alphabet key)
55	JKNBZ1715CCSA	AF	N	C	Key top (Figure key)

2 Main PWB unit

NO.	PARTS CODE	PRICE RANK	NEW MARK	PART RANK	DESCRIPTION
1	DUNT-8038CCZZ	AX		E	LCD unit
2	MSPRC1277CCZZ	AA		C	Connector spring (for 15pin connector)
3	PGUMS1550CCZZ	AC		C	LCD connector
4	PZETL1313CCZZ	AA		C	Spacer for battery terminal(Round)
5	QCNCW1368CC1E	AM		C	Connector (15pin)
6	QTANZ1289CCZZ	AB		C	Battery terminal
7	RC-CZ1021CCZZ	AB		C	Capacitor (0.1μF)
8	RC-CZ1035CCZZ	AC		C	Capacitor (100pF)
9	RC-CZ1037CCZZ	AB		C	Capacitor (0.01μF)
10	RC-CZ1047CCZZ	AB		C	Capacitor (0.033μF)
11	RC-SZ1007CCZZ	AF		C	Capacitor (1μF)
12	RC-SZ1021CCZZ	AC		C	Capacitor (10WV 3.3μF)
13	RCRSZ1003ECZZ	AE	N	B	Crystal (768K)
14	RH-TZ1002ECZZ	AD	N	B	Transistor
15	RVR-Z2400QCZZ	AF		B	Variable resistor (20KΩ)
16	VHDDAN202K/-1	AB		B	Diode (DAN202K)
17	VHILZ92K34/-1	AN	N	B	IC (LZ92K34)
18	VHISC43537LDN	AW		B	IC (SC43537LDN)
19	VHISC61860A23	AY	N	B	IC (SC61860A23)
20	VHISC69760231	AX	N	B	IC (SC69760231)

No. 8, 9, 10 exist also here

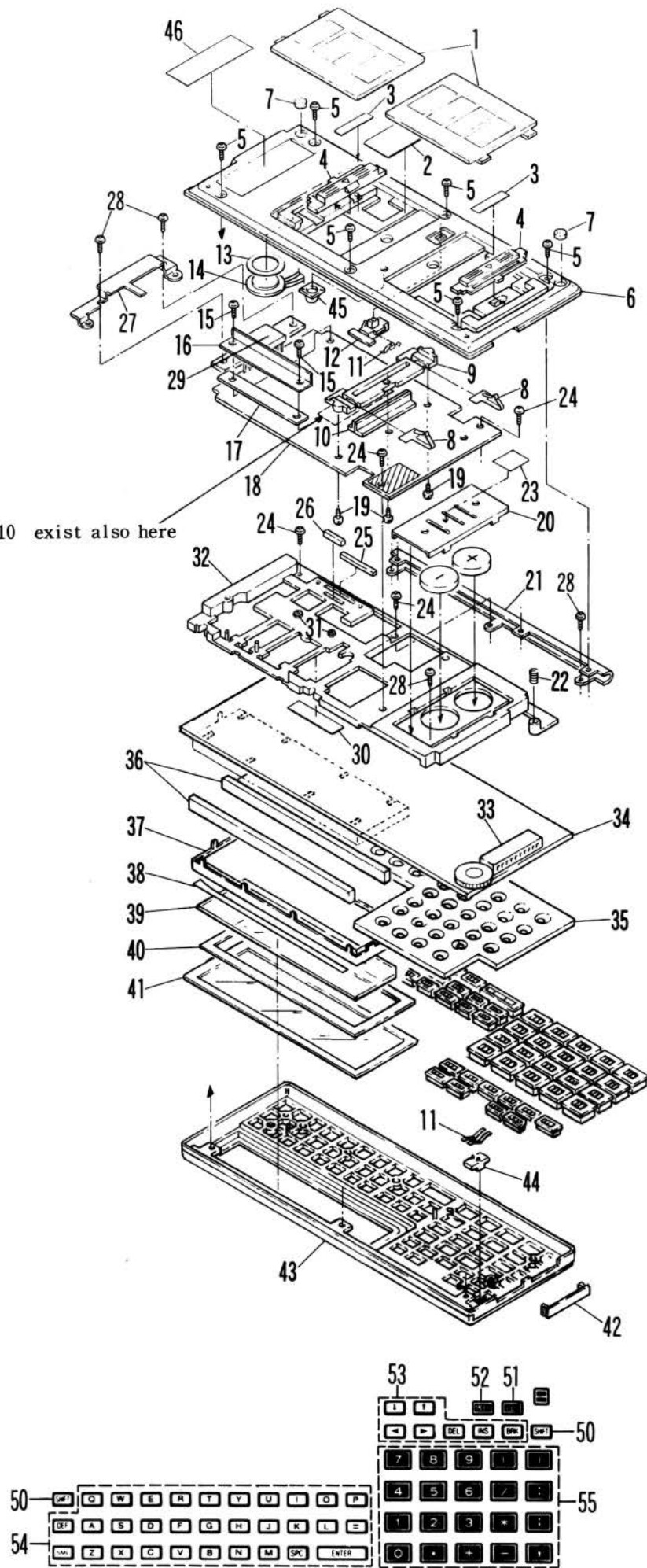

SHARP