

# SHARP SERVICE MANUAL



## CE-162E

**WWW.  
PC-1500  
.INFO**

SHARP CORPORATION

Do not sale this PDF !!!

CODE : 00ZCE162ES/ME

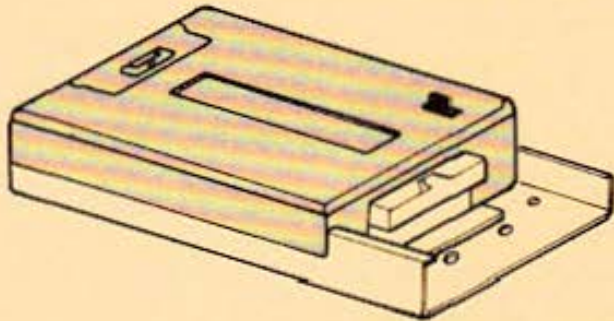

## MODEL **CE-162E**

Cassette recorder interface incorporating parallel interface for use with the PC-1500 and PC-1500A (PC-1501)

### TABLE OF CONTENTS

1. Specifications .....	1
2. System Diagram .....	3
3. CE-162E Block Diagram .....	4
4. Basic Test Program .....	4
5. Circuit Diagram .....	5
6. Parts & Signal Position .....	7
7. Parts List & Guide .....	9

File this manual into the service manual "PC-1500 & option"

# 1. SPECIFICATIONNS

- Model: CE-162E
- **Serial cassette interface**

This interface is for use with the tape recorder that meets the following requirements.

Item	Requirements
Type	Cassette tape recorder, microcassette tape recorder, and open reel tape recorder, and tape deck.
Input terminals <ul style="list-style-type: none"> <li>• Input impedance</li> <li>• Minimum input level</li> </ul>	The MIC jack or the jack equivalent to it must be available. (Mini-jack) NOTE: The AUX jack is not usable. The jack must be for use with impedance of 200 to 1 Kohms, or low impedance. Less than 3mV or -50dB.
Output terminal <ul style="list-style-type: none"> <li>• Output impedance</li> <li>• Output level</li> </ul>	The EXT. SPEAKER jack or MONITOR jack, or EAR-PHONE jack must be available. (Mini-jack) The impedance of the above jack must be less than 10ohms. More than 1V (practical maximum output more than 100mW).
Distortion (including phase distortion)	Within 15% (at same phase and 2KHz to 4KHz range)
Wow and flutter	Within 0.3% (W.R.M.S.) NOTE: Wow and flutter may increase when an impact or shock is given to the tape recorder.
Other	Should not have an extreme rotation fluctuation.

NOTE: Some of tape recorders may not satisfy the requirements or may not operate satisfactorily due to a change in electrical characteristics like output deterioration, distortion, and noise increase when used for a long period.

• Parallel printer interface

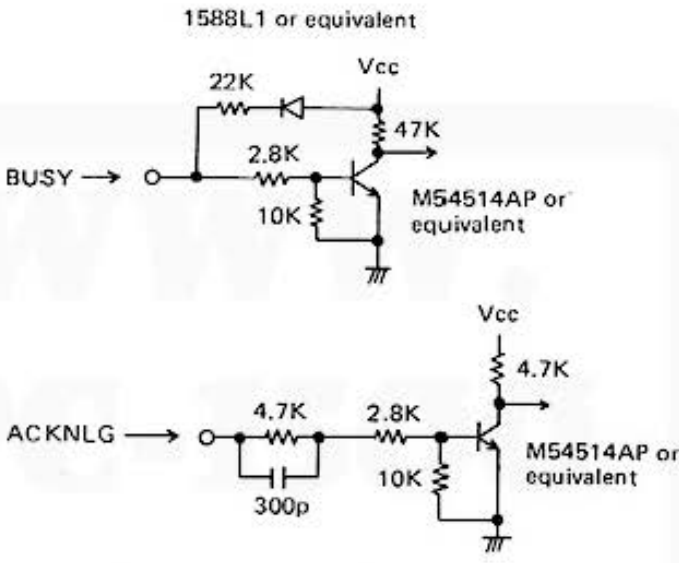
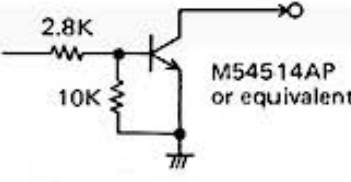
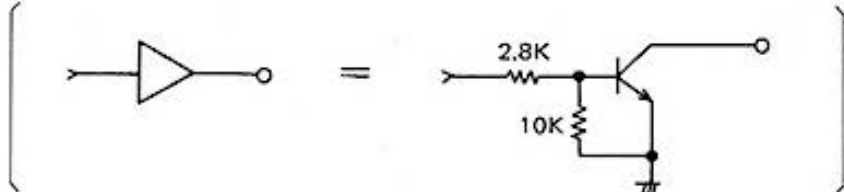
Item	Requirements
Output format	8-bit parallel output
Synchronization	By externally supplied strobe pulse
Data transfer	Handshaked (connected with BUSY signal)
Data transfer speed	222 CPS, max.
Applicable code system	JIS 8-channel code/JIS 7-channel code
Electrical signal conditions	<p>1) Signal level                      Input signals: TTL compatible                      Output signals: TTL compatible (can drive up to one TTL IC.)</p> <p>2) Input/output conditions</p> <ul style="list-style-type: none"> <li>• Input signals</li> </ul> <div style="text-align: center;">  </div> <ul style="list-style-type: none"> <li>• Output signals</li> </ul> <div style="text-align: center;">  </div> <div style="text-align: center; margin-top: 20px;">  </div> <p>Since all outputs are open collector outputs, pull-up resistors (1 K<math>\Omega</math> to 10 K<math>\Omega</math>) are required on the printer.</p>
Power supply	<p>1.5V = (DC) dry battery in size AA x 1                      (Power supply for remote control)                      The interface circuit driving power is supplied from the PC-1500/1501.</p>

- Operating temperatures: 0°C to 40°C
- Outer dimensions: 145(W) (body 115mm) x 27 (H) x 90(D)mm
- Weight: 370g (including battery)
- Accessories: Dry battery, screw x 2, Operation Manual
- When the CE-162E is attached to the PC-1500/1500A computer, the characters in this character set can be displayed or used on the computer.

CHARACTER SET  
First 4 bits →

Second 4 bits →	0	1	2	3	4	5	6	7
0			SP4 CF	0	@	P		p
1			!	1	A	Q	a	q
2			"	2	B	R	b	r
3			#	3	C	S	c	s
4			\$	4	D	T	d	t
5			⌘	5	E	U	e	u
6			&	6	F	V	f	v
7			□	7	G	W	g	w
8			(	8	H	X	h	x
9			)	9	I	Y	i	y
A			*	:	J	Z	j	z
B			+	:	K	√	k	!
C			.	<	L	¥	!	!
D			-	=	M	π	m	!
E			.	>	N	^	n	~
F			/	?	O	_	o	■

## 2. SYSTEM DIAGRAM

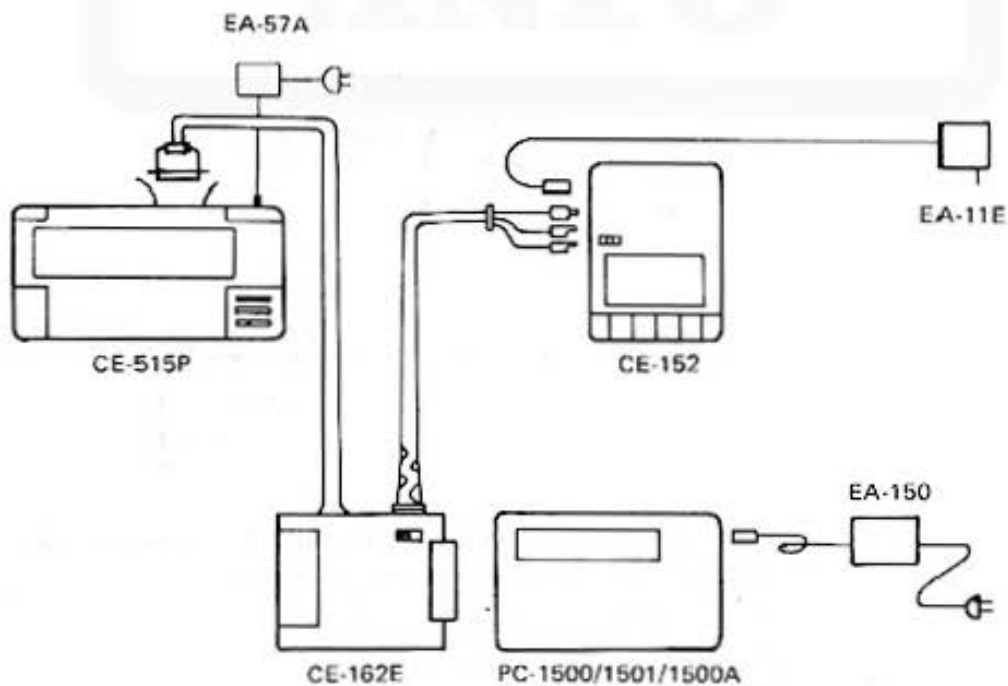



### 3. CE-162E BLOCK DIAGRAM

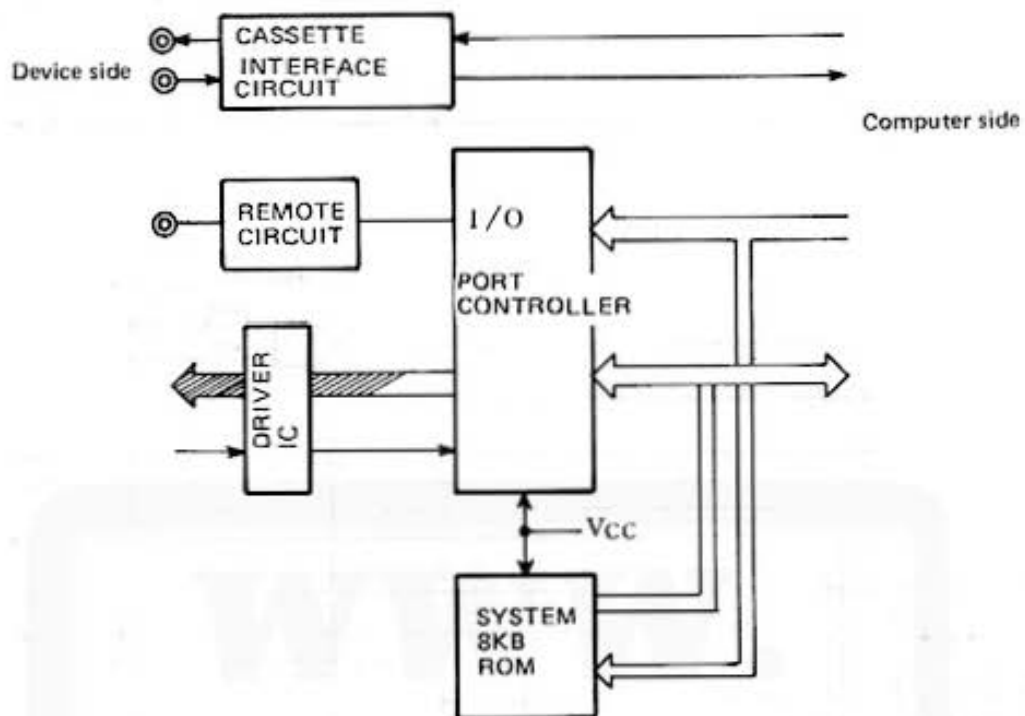

SYSTEM ROM (A000H ~ BFFFH) : LH536706  
 I/O PORT CONTROLLER : LH5811  
 CMT I/F CIRCUIT  
 REMOTE CIRCUIT

### 4. BASIC TEST PROGRAM (parallel interface)

1. Put the computer, CE-162E, and CE-515P into connection.
2. Execute the following program.

```
210 A$="":A$=INKEY$ :IF A$=""GOTO 210
220 IF A$=CHR$ 13CLS
230 WAIT 10:PRINT A$::LPRINT A$::GOTO 210
```

3. Push from the **Q** key throughout the **+** key and make sure that respective letters are printed.

QWERTYUIOP789/ASDFGHJKL456\*ZXCVBNM()123-  
 0. =+

## 5. CIRCUIT DIAGRAM

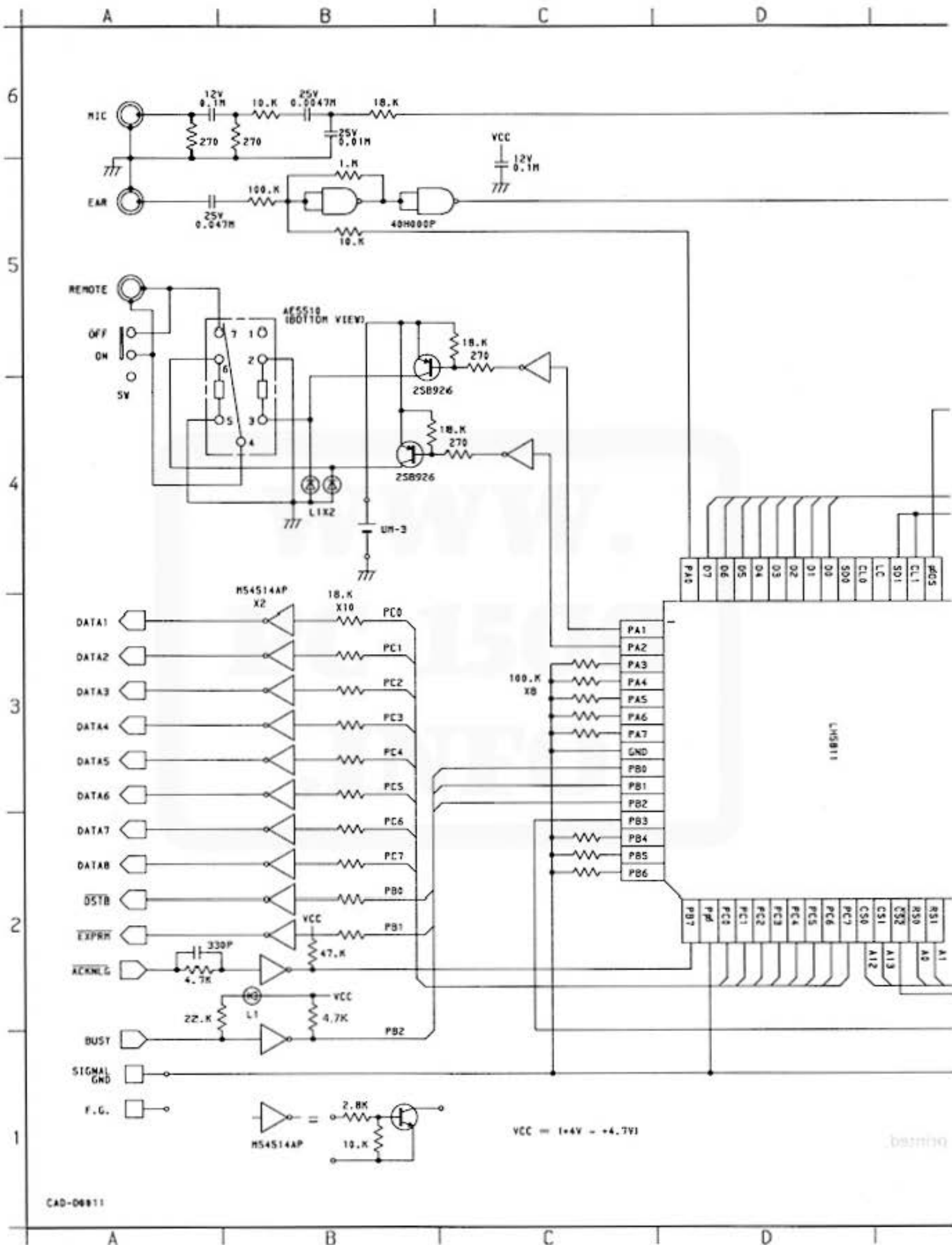

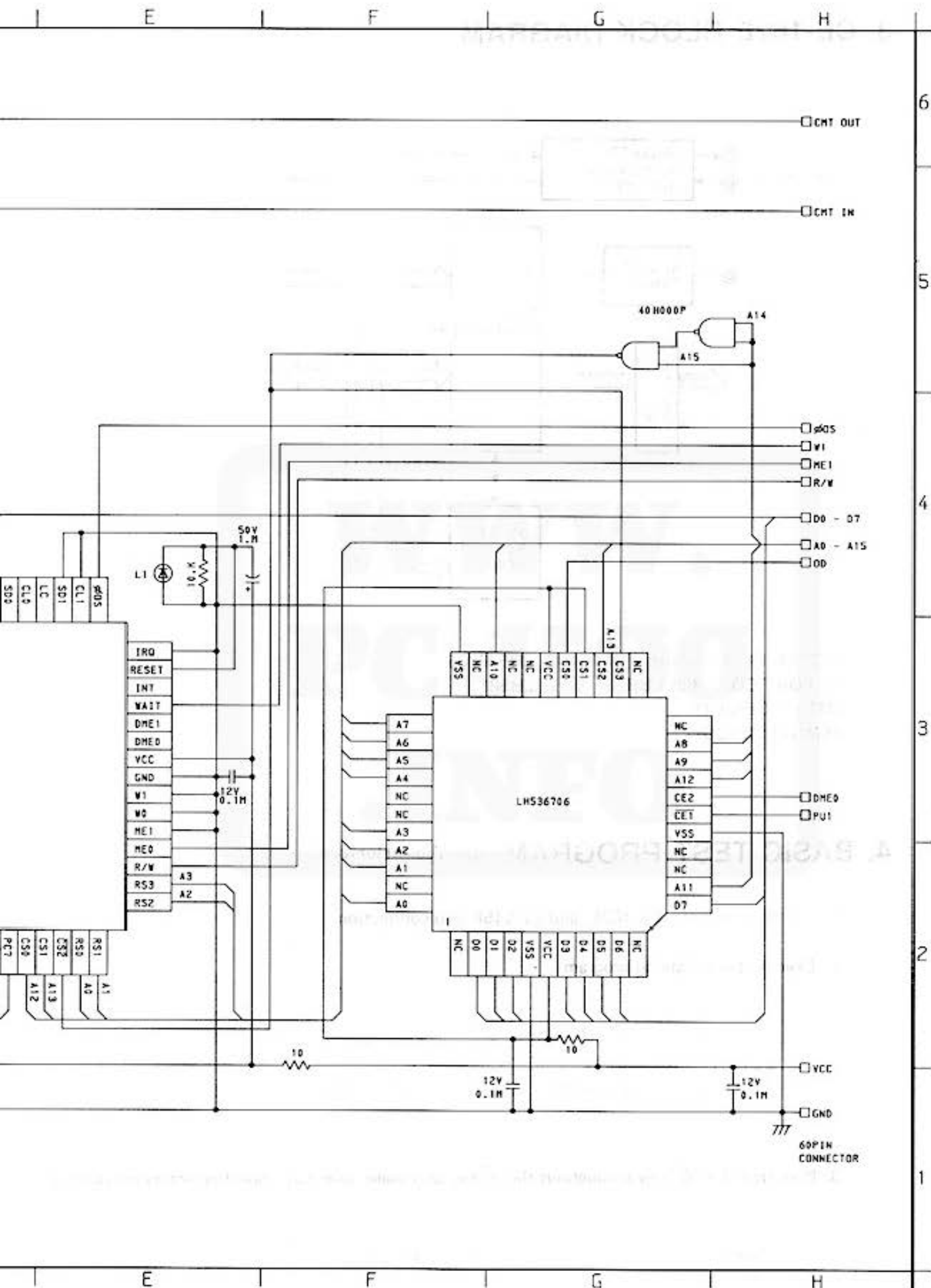



## 6. PARTS & SIGNAL POSITION

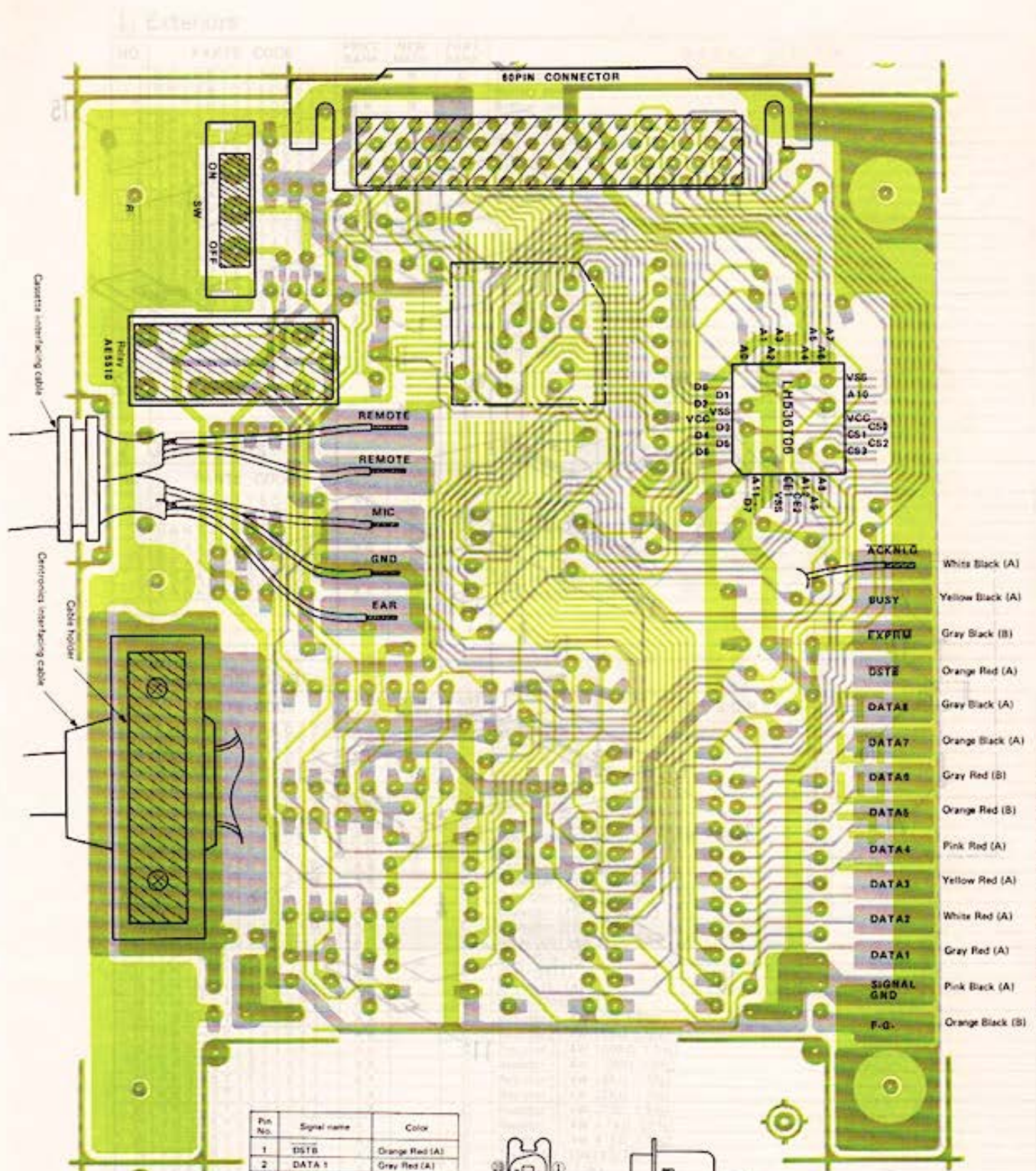

Pin No.	Signal name	Color
1	DSTB	Orange Red (A)
2	DATA 1	Gray Red (A)
3	DATA 2	White Red (A)
4	DATA 3	Yellow Red (A)
5	DATA 4	Pink Red (A)
6	DATA 5	Orange Red (B)
7	DATA 6	Gray Red (B)
8	DATA 7	Orange Black (A)
9	DATA 8	Gray Black (A)
10	ACKNLG	White Black (A)
11	BUSY	Yellow Black (A)
16	SIGNAL GND	Pink Black (A)
17	F.G.	Orange Black (A)
21	EXPRM	Gray Black (B)

⊙ (A) represents a single dot mark and (B) two dots mark.

\* (A) represents a single dot mark (B) two dots mark.



7. PARTS LIST & GUIDE

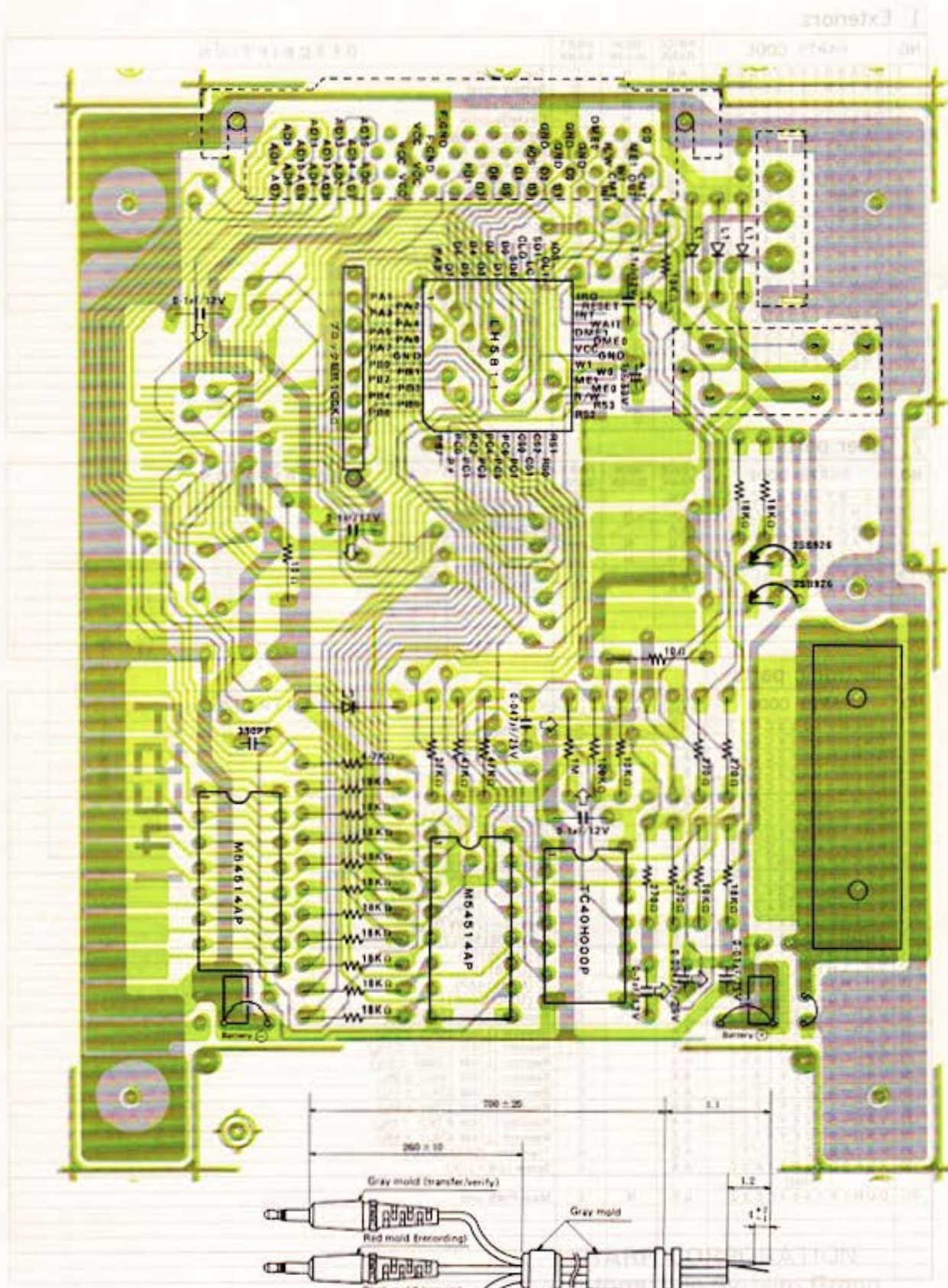

Quality & Reliability Control Center  
Yamato Industry, Nara 639-11, Japan

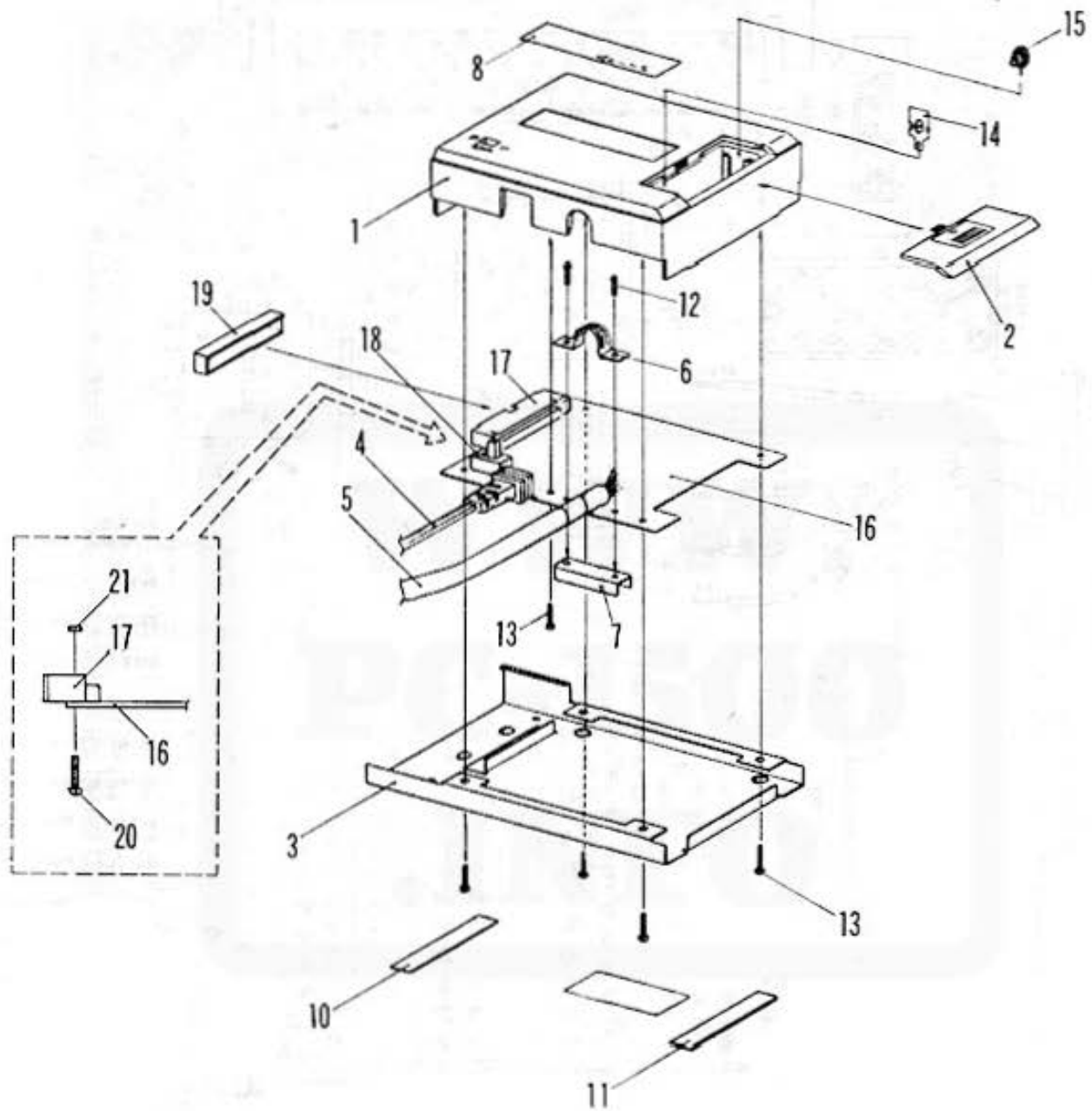

**SHARP CORPORATION**  
Information Systems Group  
Quality & Reliability Control Center  
Yamatokoriyama, Nara 639-11, Japan

1985 May Printed in Japan ©