

# SHARP SERVICE MANUAL



## CE-155

**WWW.  
PC-1500  
.INFO**

SHARP CORPORATION

Do not sale this PDF !!!

**MODEL CE-155**

**8KB RAM MODULE**

(PC-1500 OPTION)

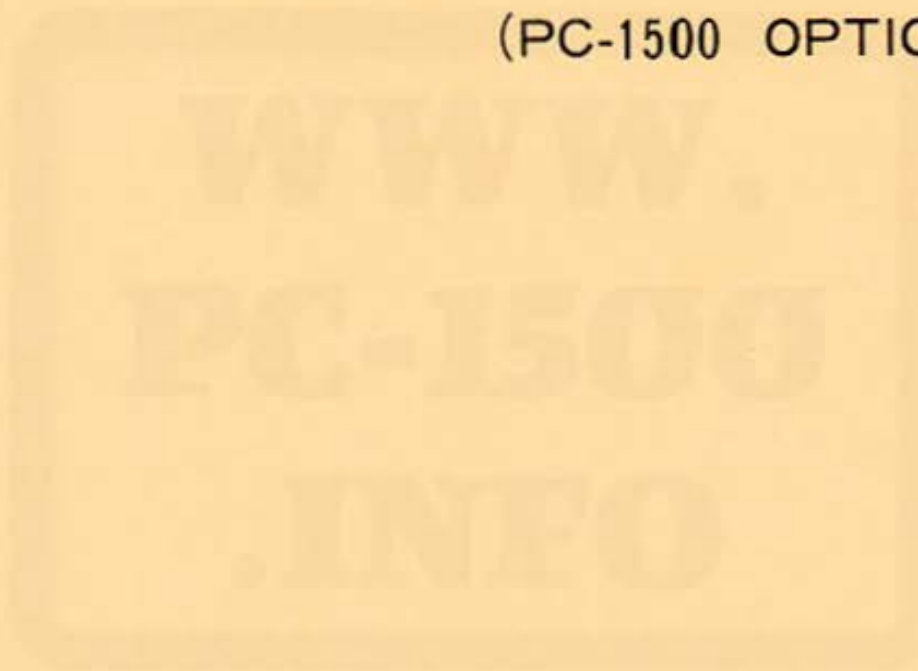

File this manual into the service manual "PC-1500 & OPTION"

## 1. Outline

It is the option 8KB RAM that can be used for the PC-1500.

## 2. RAM address

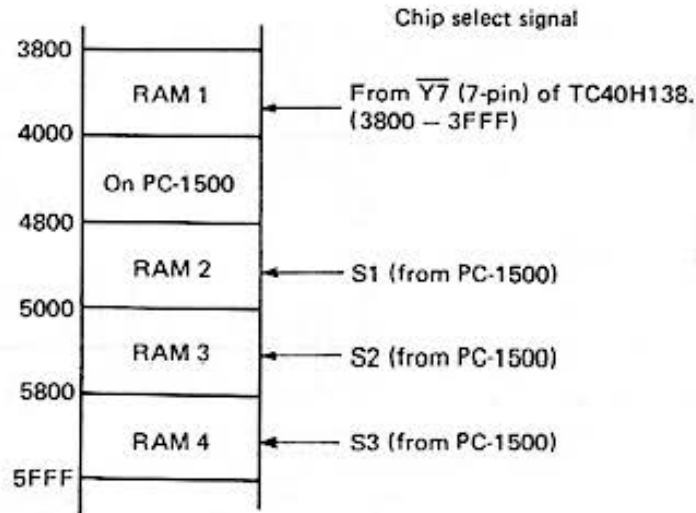

## 3. Circuit description

RAM1 chip select

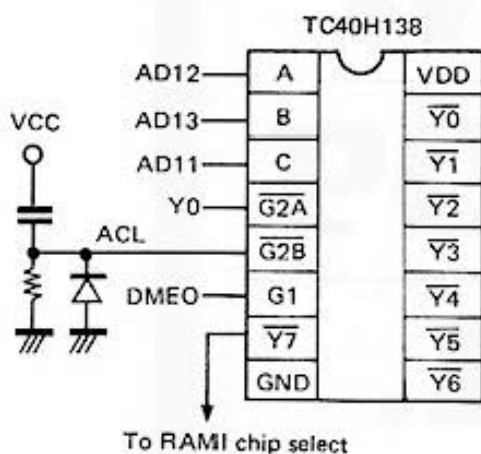

The RAM1 is selected with a low state of  $\overline{Y7}$  which is issued when all of A, B, and C, are high with high state of G1 and low state of decoder IC (TC40H138) gate inputs,  $\overline{G2A}$  and  $\overline{G2B}$ .

In other words, the RAM1 Chip Select ( $\overline{CS}$ ) turns low state to select the RAM1 in the following conditions:

Y0, ACL: low

DME0, AD11, AD12, AD13: high

The signal ACL, however, is the RAM contents protective signal at the time of power-on.

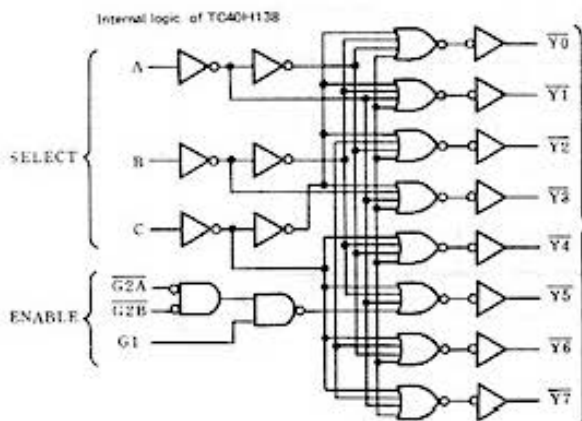

Truth table

Input						Output							
01	ENABLE		SELECT			Y0	Y1	Y2	Y3	Y4	Y5	Y6	Y7
L	X	X	X	X	X	H	H	H	H	H	H	H	H
X	H	X	X	X	X	H	H	H	H	H	H	H	H
X	X	H	X	X	X	H	H	H	H	H	H	H	H
H	L	L	L	L	L	L	H	H	H	H	H	H	H
H	L	L	L	L	H	L	L	H	H	H	H	H	H
H	L	L	L	L	H	L	H	L	H	H	H	H	H
H	L	L	L	H	L	H	H	L	L	H	H	H	H
H	L	L	L	H	H	H	H	H	L	L	H	H	H
H	L	L	L	H	H	H	H	H	H	L	L	H	H
H	L	L	L	H	H	H	H	H	H	H	L	L	H
H	L	L	L	H	H	H	H	H	H	H	H	L	L

X : Don't care

## 4. CIRCUIT DIAGRAM

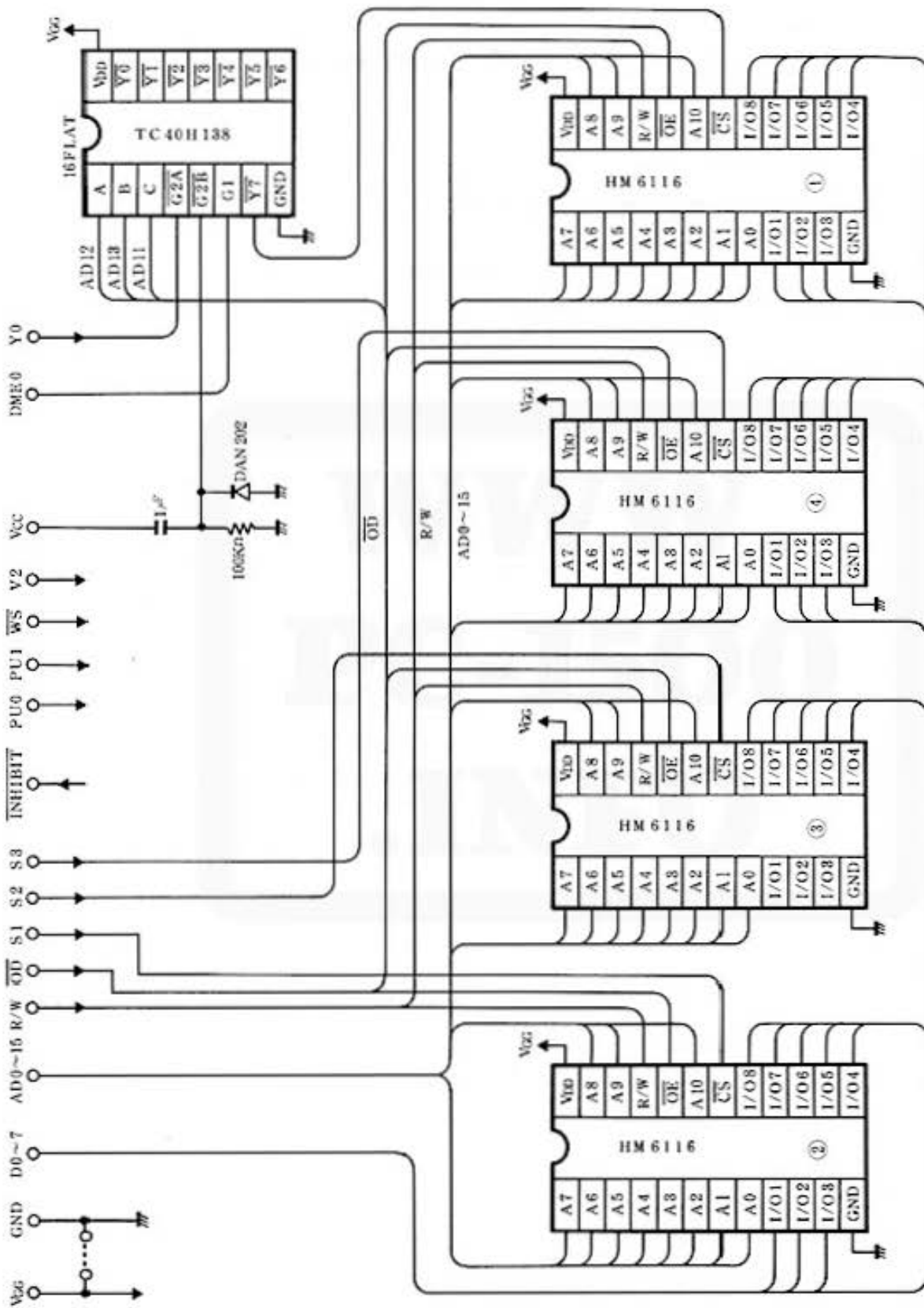

## 5. PARTS & SIGNALS POSITION

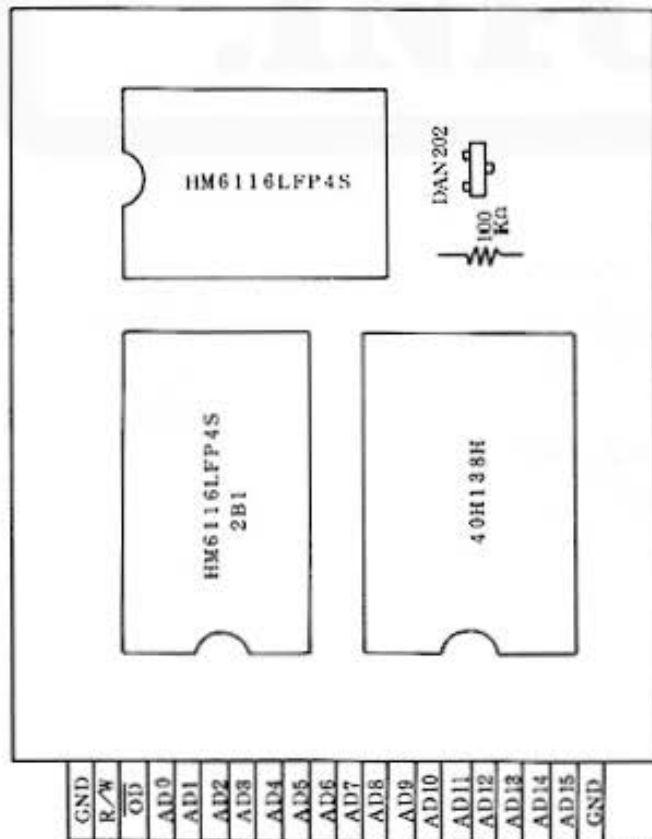
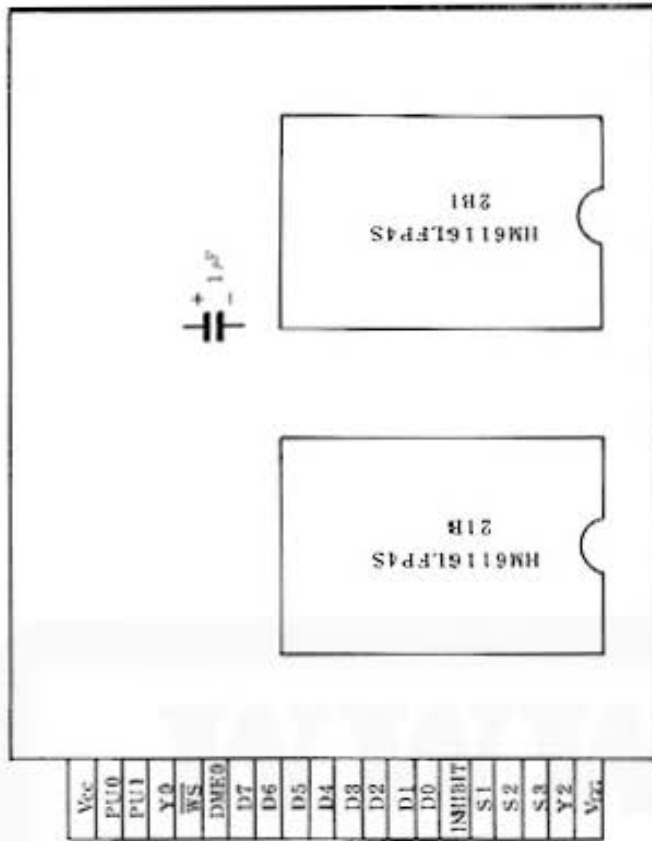

## 6. PARTS LIST & GUIDE

NO.	PARTS CODE	DESCRIPTION	NEW MARK	PARTS RANK	PRICE RANK
1	GCABA2637CCZZ	Bottom cabinet	N	D	A C
2	GCABB2638CCZZ	Top cabinet	N	D	A C
3	GCASPI078CCZZ	Module case		D	A C
4	GFTAUI243CCZZ	Module case cover		D	A D
5	PCUSUI176CCZZ	Cushion		D	A A
6	PHOG-1092CCZZ	Short rubber		D	A C
7	TCAUHI179CCZZ	Caution label		D	A B
8	TLABZI642CCZZ	Module label		D	A A
9	SPAKC7002CCZZ	Packing case	N	D	A D
10	DUNTK6669CCZZ	PWB unit	N	E	B W
	VHiHM6116// -1	LSi		B	B E
	VHiTC40H138FN	iC		B	A 0
	RC-SZ1003CCNA	Capacitor		C	A C
	RH-DZ1008CCNI	Diode		B	A C
	VRS-TP2BD104J	Resistor		C	A A
	TiNSM3546CCZZ	Instruction book	N	D	A C

